

## Rondelles convexes / concaves • similaires à la norme DIN 6319, en inox EH 23050.



### Description produit

Les rondelles convexes/concaves sont utilisées dans les raccords vissés pour équilibrer les surfaces non parallèles.

### Matières

#### Rondelle concave

- inox 1.4305
- inox A4

#### Rondelle convexe

- inox 1.4305
- inox A4

### Assemblage

Rondelles concaves forme D : à n'utiliser que pour des surfaces planes, ou sphériques fermées.

Pour trous oblongs : n'utiliser que la forme G!

### Caractéristique

Version inox A4 avec marquage (moletage) selon plan.

### Plus d'informations

### Autres produits

- Rondelles convexes / concaves, DIN 6319
- Écrous six pans, DIN 6330 (hauteur 1,5 d)

### Plan

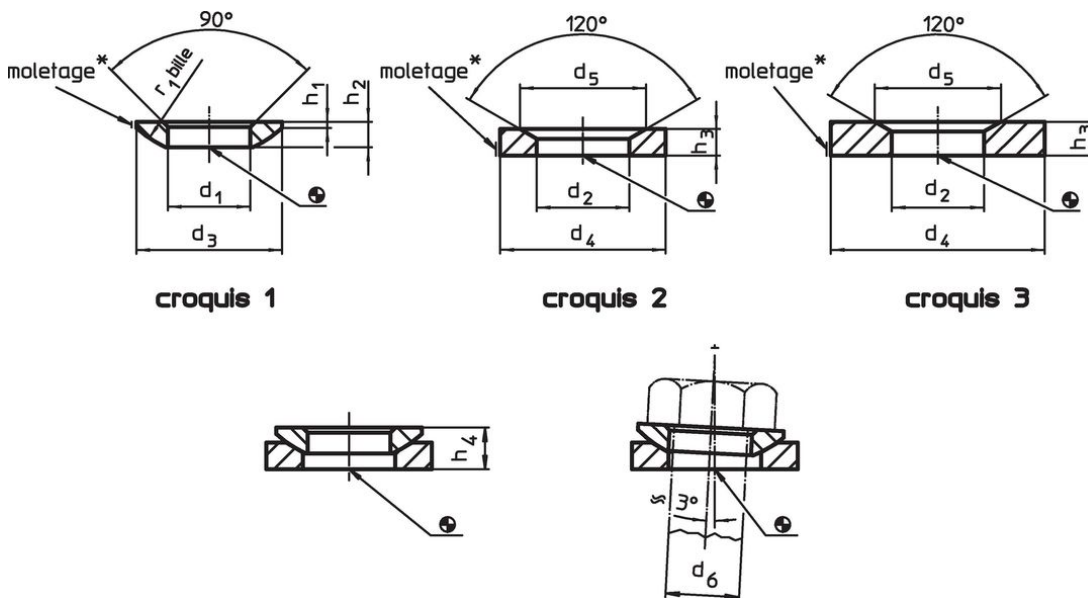

\* Moletage: identification pour inox A4

### Informations détaillées

Dimensions											Pour boulon d <sub>6</sub>	Pour vis d <sub>6</sub>	Charge admissible pour utilisation statique max.	Moment de rotation pour assemblages vissés <sup>1)</sup> max.	Référence article	
d <sub>1</sub> H13	d <sub>2</sub> H13	d <sub>3</sub>	d <sub>4</sub>	d <sub>5</sub>	h <sub>1</sub>	h <sub>2</sub>	h <sub>3</sub>	h <sub>4</sub>		r <sub>1</sub>						
[mm]											[mm]	[mm]	[kN]	[Nm]	[g]	
											avec rondelle concave, forme D ~	avec rondelle concave, forme G ~				
<b>rondelles convexes en inox, forme C – croquis 1, inox 1.4305</b>																
6,4	–	12	–	–	0,7	2,3	–	4,0	5,2	9	6	M 6	6	6	1,0	<a href="#">23050.0306</a>
8,4	–	17	–	–	0,6	3,2	–	5,3	6,8	12	8	M 8	12	16	2,8	<a href="#">23050.0308</a>
10,5	–	21	–	–	0,8	4,0	–	6,3	7,1	15	10	M10	16	32	5,0	<a href="#">23050.0310</a>
13,0	–	24	–	–	1,1	4,6	–	7,9	8,9	17	12	M12	24	56	7,7	<a href="#">23050.0312</a>
17,0	–	30	–	–	1,3	5,3	–	9,3	10,1	22	16	M16	45	135	13,0	<a href="#">23050.0316</a>
21,0	–	36	–	–	2,0	6,3	–	11,6	12,1	27	20	M20	71	280	23,0	<a href="#">23050.0320</a>

<sup>1)</sup> Indication du couple pour les vis à taraudage normal, le cas échéant tenir compte de la précharge, coefficient de frottement  $\mu_{total}$  0,14.

d <sub>1</sub> H13	d <sub>2</sub> H13	d <sub>3</sub>	d <sub>4</sub>	d <sub>5</sub>	Dimensions					r <sub>1</sub>	Pour boulon d <sub>6</sub>	Pour vis d <sub>6</sub>	Charge admissible pour utilisation statique max.	Moment de rotation pour assemblages vissés <sup>1)</sup> max.		Référence article
					h <sub>1</sub>	h <sub>2</sub>	h <sub>3</sub>	h <sub>4</sub>								
25,0	–	44	–	–	2,4	8,2	–	14,9	15,4	32	24	M24	105	455	46,0	23050.0324
31,0	–	56	–	–	3,6	11,2	–	18,8	18,8	41	30	M30	191	1050	104,0	23050.0330
37,0	–	68	–	–	4,6	14,0	–	23,4	–	50	36	M36	–	–	193,0	23050.0336
43,0	–	78	–	–	6,5	17,0	–	28,3	–	58	42	M42	–	–	313,0	23050.0342
50,0	–	92	–	–	8,0	21,0	–	35,0	–	67	48	M48	–	–	545,0	23050.0348
<b>rondelles convexes en inox, forme C – croquis 1, inox A4</b>																
6,4	–	12	–	–	0,7	2,3	–	4,0	5,2	9	6	M 6	6	6	1,0	23050.0606
8,4	–	17	–	–	0,6	3,2	–	5,3	6,8	12	8	M 8	12	16	2,8	23050.0608
10,5	–	21	–	–	0,8	4,0	–	6,3	7,1	15	10	M10	16	32	5,0	23050.0610
13,0	–	24	–	–	1,1	4,6	–	7,9	8,9	17	12	M12	24	56	7,7	23050.0612
17,0	–	30	–	–	1,3	5,3	–	9,3	10,1	22	16	M16	45	135	13,0	23050.0616
21,0	–	36	–	–	2,0	6,3	–	11,6	12,1	27	20	M20	71	280	23,0	23050.0620
25,0	–	44	–	–	2,4	8,2	–	14,9	15,4	32	24	M24	105	455	46,0	23050.0624
31,0	–	56	–	–	3,6	11,2	–	18,8	18,8	41	30	M30	191	1050	104,0	23050.0630
37,0	–	68	–	–	4,6	14,0	–	23,4	–	50	36	M36	–	–	193,0	23050.0636
43,0	–	78	–	–	6,5	17,0	–	28,3	–	58	42	M42	–	–	313,0	23050.0642
50,0	–	92	–	–	8,0	21,0	–	35,0	–	67	48	M48	–	–	545,0	23050.0648
<b>rondelles concaves en inox, forme D – croquis 2, inox 1.4305</b>																
–	7,1	–	12	11,0	–	–	2,8	–	–	–	6	M 6	6	6	1,3	23050.0406
–	9,6	–	17	14,5	–	–	3,5	–	–	–	8	M 8	12	16	3,7	23050.0408
–	12,0	–	21	18,5	–	–	4,2	–	–	–	10	M10	16	32	6,6	23050.0410
–	14,2	–	24	20,0	–	–	5,0	–	–	–	12	M12	24	56	10,0	23050.0412
–	19,0	–	30	26,0	–	–	6,2	–	–	–	16	M16	45	135	19,0	23050.0416
–	23,2	–	36	31,0	–	–	7,5	–	–	–	20	M20	71	280	32,0	23050.0420
–	28,0	–	44	37,0	–	–	9,5	–	–	–	24	M24	105	455	63,0	23050.0424
–	35,0	–	56	49,0	–	–	12,0	–	–	–	30	M30	191	1050	127,0	23050.0430
–	42,0	–	68	60,0	–	–	15,0	–	–	–	36	M36	–	–	234,0	23050.0436
–	49,0	–	78	70,0	–	–	18,0	–	–	–	42	M42	–	–	362,0	23050.0442
–	56,0	–	92	82,0	–	–	22,0	–	–	–	48	M48	–	–	642,0	23050.0448
<b>rondelles concaves en inox, forme D – croquis 2, inox A4</b>																
–	7,1	–	12	11,0	–	–	2,8	–	–	–	6	M 6	6	6	1,3	23050.0666
–	9,6	–	17	14,5	–	–	3,5	–	–	–	8	M 8	12	16	3,7	23050.0668
–	12,0	–	21	18,5	–	–	4,2	–	–	–	10	M10	16	32	6,6	23050.0670
–	14,2	–	24	20,0	–	–	5,0	–	–	–	12	M12	24	56	10,0	23050.0672
–	19,0	–	30	26,0	–	–	6,2	–	–	–	16	M16	45	135	19,0	23050.0676
–	23,2	–	36	31,0	–	–	7,5	–	–	–	20	M20	71	280	32,0	23050.0680
–	28,0	–	44	37,0	–	–	9,5	–	–	–	24	M24	105	455	63,0	23050.0684
–	35,0	–	56	49,0	–	–	12,0	–	–	–	30	M30	191	1050	127,0	23050.0686
–	42,0	–	68	60,0	–	–	15,0	–	–	–	36	M36	–	–	234,0	23050.0688
–	49,0	–	78	70,0	–	–	18,0	–	–	–	42	M42	–	–	362,0	23050.0692
–	56,0	–	92	82,0	–	–	22,0	–	–	–	48	M48	–	–	642,0	23050.0694
<b>rondelles concaves en inox, forme G – croquis 3, inox 1.4305</b>																
–	7,1	–	17	11,0	–	–	4,0	–	–	–	6	M 6	6	6	5,8	23050.0466
–	9,6	–	24	14,5	–	–	5,0	–	–	–	8	M 8	12	16	15,0	23050.0468
–	12,0	–	30	18,5	–	–	5,0	–	–	–	10	M10	16	32	22,0	23050.0470
–	14,2	–	36	20,0	–	–	6,0	–	–	–	12	M12	24	56	40,0	23050.0472
–	19,0	–	44	26,0	–	–	7,0	–	–	–	16	M16	45	135	66,0	23050.0476
–	23,2	–	50	31,0	–	–	8,0	–	–	–	20	M20	71	280	95,0	23050.0480
–	28,0	–	60	37,0	–	–	10,0	–	–	–	24	M24	105	455	171,0	23050.0484
–	35,0	–	68	49,0	–	–	12,0	–	–	–	30	M30	191	1050	236,0	23050.0490
<b>rondelles concaves en inox, forme G – croquis 3, inox A4</b>																
–	7,1	–	17	11,0	–	–	4,0	–	–	–	6	M 6	6	6	5,8	23050.0706
–	9,6	–	24	14,5	–	–	5,0	–	–	–	8	M 8	12	16	15,0	23050.0708
–	12,0	–	30	18,5	–	–	5,0	–	–	–	10	M10	16	32	22,0	23050.0710
–	14,2	–	36	20,0	–	–	6,0	–	–	–	12	M12	24	56	40,0	23050.0712

<sup>1)</sup> Indication du couple pour les vis à taraudage normal, le cas échéant tenir compte de la précharge, coefficient de frottement  $\mu_{\text{total}} 0,14$ .

d <sub>1</sub> H13	d <sub>2</sub> H13	d <sub>3</sub>	d <sub>4</sub>	d <sub>5</sub>	Dimensions					r <sub>1</sub>	Pour boulon d <sub>6</sub>	Pour vis d <sub>6</sub>	Charge admissible pour utilisation statique max.	Moment de rotation pour assemblages vissés <sup>1)</sup> max.	Référence article	
					h <sub>1</sub>	h <sub>2</sub>	h <sub>3</sub>	avec rondelle concave, forme D ~	avec rondelle concave, forme G ~							h <sub>4</sub>
-	19,0	-	44	26,0	-	-	7,0	-	-	-	16	M16	45	135	66,0	23050.0716
-	23,2	-	50	31,0	-	-	8,0	-	-	-	20	M20	71	280	95,0	23050.0720
-	28,0	-	60	37,0	-	-	10,0	-	-	-	24	M24	105	455	171,0	23050.0724
-	35,0	-	68	49,0	-	-	12,0	-	-	-	30	M30	191	1050	236,0	23050.0730

<sup>1)</sup> Indication du couple pour les vis à taraudage normal, le cas échéant tenir compte de la précharge, coefficient de frottement  $\mu_{\text{total}}$  0,14.

### Exemple d'application

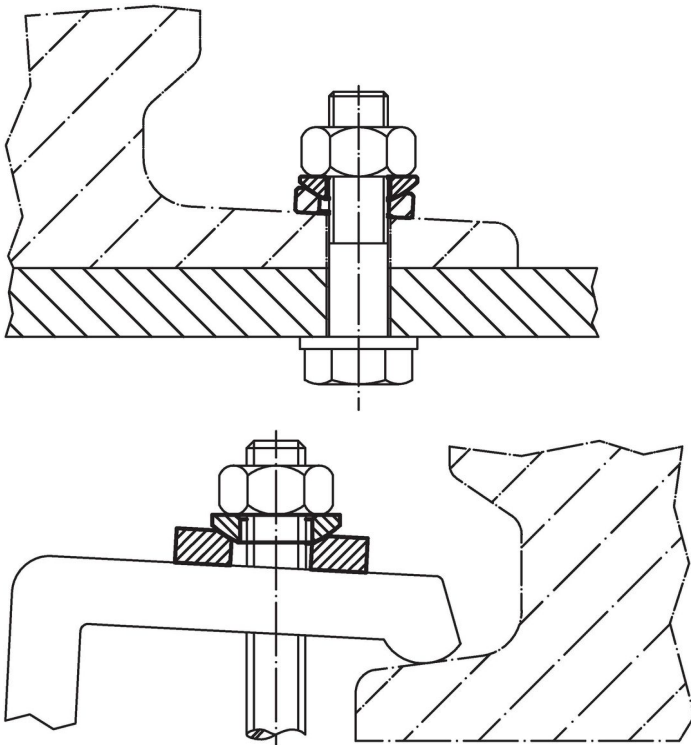

### Conformité

#### Conforme à la directive RoHS

Conforme à la directive 2011/65/CE et à la directive 2015/863.

#### Ne contient pas de substances SVHC

Pas de substances SVHC avec une teneur supérieure à 0,1% m/m – Liste SVHC [REACH] au 27.06.2024.

#### Ne contient pas de substances de la Proposition 65

Aucune des substances de la Proposition 65 présente.

<https://www.P65Warnings.ca.gov/>

#### Ne contient pas de minerais de la guerre

Ce produit ne contient pas de substances classées comme "minerais de la guerre" telles que le tantale, l'étain, l'or ou le wolfram provenant de République démocratique du Congo ou de pays frontaliers.