

Lateral Plungers · with plastic spring and pin - INCH

EH 2B150.



Product Description

To be used for positioning and applying pressure, e.g. during painting and sandblasting.

Material

Body

- Aluminium Al

Spring

- plastic

Pin

- Steel, case-hardened, blackened
- Stainless steel
- Thermoplastic POM, white

Assembly

Installation by pressing in.

Formula for calculating the center distance for the mounting hole:

$$l_0 = z/2 + w + x,$$

l_0 = center distance,

y = workpiece height,

w = workpiece length,

x = coordinate dimension,

s = stroke,

z = stop diameter

Calculation dimension x :

y greater than or equal to $l_2 - d_2/2$,

then $x = d_2/2 - s$

(value x for this case see table)

or

y smaller than $l_2 - d_2/2$,

then $x = d_2/2 - s - [(l_2 - d_2/2 - y) * 0,123]$

Characteristic

Version light spring load = blue spring

Version standard spring load = red spring

Version heavy spring load = green spring

More information

Notes

This is a discontinued article.

Drawing

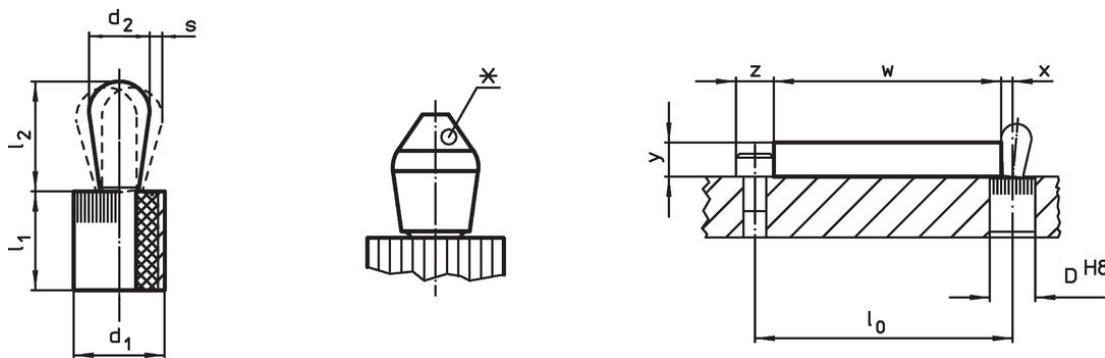

*some sizes (see chart) have a deviating pin shape

Order information

Dimensions		Spring load F max. ¹⁾ ~ [lb]	Dimensions		Stroke s [in]	Location hole D H8 [in]	x ²⁾ [in]	max. [°F]	[oz]	Art. No.
d ₁	d ₂		l ₁	l ₂						
[in]			[in]							
Pin: Steel/Light spring load										
1/4	0.118	2.2	0.295	0.145	0.008	0.250	0.051	212	0.020	2B150.0210 ³⁾
7/16	0.197	6.7	0.374	0.287	0.016	0.438	0.083	212	0.092	2B150.0220
7/16	0.236	4.4	0.374	0.406	0.020	0.438	0.098	212	0.120	2B150.0225

¹⁾ statistical average value

²⁾ If the workpiece height (y) is less than $l_2 - d_2/2$, the coordinate dimension (x) must be calculated.

³⁾ deviating pin shape (see drawing)



Dimensions		Spring load F max. ¹⁾ ~ [lb]	Dimensions		Stroke s [in]	Location hole D H8 [in]	x ²⁾ [in]	max. [°F]	 [oz]	Art. No.
d ₁ [in]	d ₂ [in]		l ₁ -0.03 [in]	l ₂ ±0.02 [in]						
Pin: Steel/Standard spring load										
1/4	0.118	4.4	0.295	0.145	0.008	0.250	0.051	212	0.020	2B150.0211 ³⁾
7/16	0.197	13.5	0.374	0.287	0.016	0.438	0.083	212	0.092	2B150.0221
7/16	0.236	6.7	0.374	0.406	0.020	0.438	0.098	212	0.120	2B150.0226
1/2	0.315	11.1	0.553	0.515	0.024	0.500	0.134	212	0.260	2B150.0230
5/8	0.394	18.0	0.675	0.678	0.031	0.625	0.166	212	0.534	2B150.0240
Pin: Steel/Heavy spring load										
7/16	0.197	20.0	0.374	0.287	0.016	0.438	0.083	212	0.092	2B150.0222
7/16	0.236	13.5	0.374	0.406	0.020	0.438	0.098	212	0.121	2B150.0227
1/2	0.315	22.2	0.553	0.515	0.024	0.500	0.134	212	0.262	2B150.0231
5/8	0.394	36.0	0.675	0.678	0.031	0.625	0.166	212	0.540	2B150.0241
Pin: Stainless steel/Light spring load										
1/4	0.118	2.2	0.295	0.145	0.008	0.250	0.051	212	0.022	2B150.0310 ³⁾
7/16	0.197	6.7	0.374	0.287	0.016	0.438	0.083	212	0.093	2B150.0320
7/16	0.236	4.4	0.374	0.406	0.020	0.438	0.098	212	0.121	2B150.0325
Pin: Stainless steel/Standard spring load										
1/4	0.118	4.4	0.295	0.145	0.008	0.250	0.051	212	0.021	2B150.0311 ³⁾
7/16	0.197	13.5	0.374	0.287	0.016	0.438	0.083	212	0.093	2B150.0321
7/16	0.236	6.7	0.374	0.406	0.020	0.438	0.098	212	0.121	2B150.0326
1/2	0.315	11.1	0.553	0.515	0.024	0.500	0.134	212	0.247	2B150.0330
5/8	0.394	18.0	0.675	0.678	0.031	0.625	0.166	212	0.543	2B150.0340
Pin: Stainless steel/Heavy spring load										
7/16	0.197	20.0	0.374	0.287	0.016	0.438	0.083	212	0.095	2B150.0322
7/16	0.236	13.5	0.374	0.406	0.020	0.438	0.098	212	0.122	2B150.0327
1/2	0.315	22.2	0.553	0.515	0.024	0.500	0.134	212	0.263	2B150.0331
5/8	0.394	36.0	0.675	0.678	0.031	0.625	0.166	212	0.546	2B150.0341
Pin: Thermoplastic/Light spring load										
1/4	0.118	2.2	0.295	0.145	0.008	0.250	0.051	176	0.013	2B150.0410 ³⁾
7/16	0.197	6.7	0.374	0.287	0.016	0.438	0.083	176	0.054	2B150.0420
7/16	0.236	4.4	0.374	0.406	0.020	0.438	0.098	176	0.058	2B150.0425
Pin: Thermoplastic/Standard spring load										
1/4	0.118	4.4	0.295	0.145	0.008	0.250	0.051	176	0.012	2B150.0411 ³⁾
7/16	0.197	13.5	0.374	0.287	0.016	0.438	0.083	176	0.052	2B150.0421
7/16	0.236	6.7	0.374	0.406	0.020	0.438	0.098	176	0.057	2B150.0426
1/2	0.315	11.1	0.553	0.515	0.024	0.500	0.134	176	0.104	2B150.0430
5/8	0.394	18.0	0.675	0.678	0.031	0.625	0.166	176	0.196	2B150.0440
Pin: Thermoplastic/Heavy spring load										
7/16	0.197	20.0	0.374	0.287	0.016	0.438	0.083	176	0.054	2B150.0422
7/16	0.236	13.5	0.374	0.406	0.020	0.438	0.098	176	0.058	2B150.0427
1/2	0.315	22.2	0.553	0.515	0.024	0.500	0.134	176	0.106	2B150.0431
5/8	0.394	36.0	0.675	0.678	0.031	0.625	0.166	176	0.200	2B150.0441

¹⁾ statistical average value

²⁾ If the workpiece height (y) is less than l2-d2/2, the coordinate dimension (x) must be calculated.

³⁾ deviating pin shape (see drawing)

Accessories

	Dimensions d ₁ [in]	 [oz]	Art. No.
assembly tool			
	1/4	0.678	22150.0830
	7/16	1.749	22150.0831
	1/2	2.321	22150.0832
	5/8	3.749	22150.0833

Compliance

For detailed compliance information please select the desired article number.