

Height-Adjusting Elements • orienting

EH 25120.



Product Description

For levelling of machines and installations when bearing surfaces are not parallel. For vertical adjustment, the self-locking height-adjusting elements are fitted with a fine-pitch thread. All elements have a throughgoing bore for fastening purposes. A turn-out lock serves as height limit for the maximum adjustment height.

Material

- Heat-treated steel, zinc-plated by galvanization, chromalized

Drawing

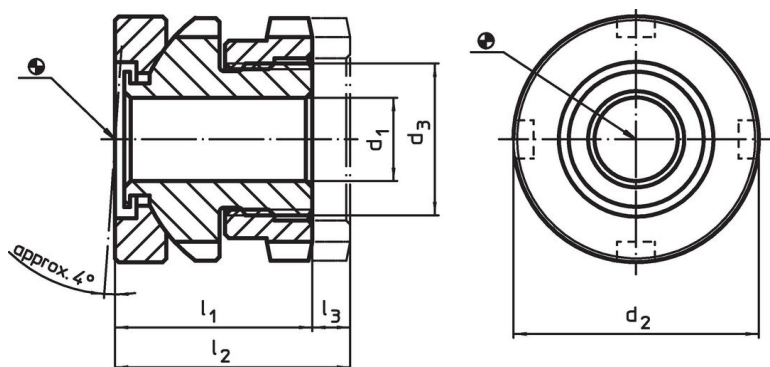

Order information

d ₁	d ₂	Dimensions d ₃ [mm]	l ₁ ~	l ₂ ~	Stroke l ₃ ~ [mm]	For screw [mm]	Load capacity for static load max. [kN]	Load capacity ¹⁾ max. [kN]	[g]	Art. No.
6.6	25	M15 x 1	22	26	4	M 6	40	30.7	66	25120.0206
6.6	32	M20 x 1	26	31	5	M 6	65	55.7	131	25120.0212
9.0	32	M20 x 1	26	31	5	M 8	65	48.0	124	25120.0214
11.0	32	M20 x 1	26	31	5	M10	65	37.9	117	25120.0216
11.0	45	M30 x 1,5	34	41	7	M10	120	92.9	340	25120.0222
13.5	45	M30 x 1,5	34	41	7	M12	120	80.4	320	25120.0224
17.5	45	M30 x 1,5	34	41	7	M16	120	45.5	324	25120.0226
17.5	58	M40 x 1,5	44	53	9	M16	210	136.0	775	25120.0232
22.0	58	M40 x 1,5	44	53	9	M20	210	90.0	641	25120.0234
26.0	58	M40 x 1,5	44	53	9	M24	210	37.0	683	25120.0236
22.0	70	M50 x 1,5	50	60	10	M20	330	210.0	1157	25120.0242
26.0	70	M50 x 1,5	50	60	10	M24	330	157.0	1114	25120.0244
33.0	70	M50 x 1,5	50	60	10	M30	330	53.0	990	25120.0246

¹⁾ Load capacity after deduction of the maximum preload force for screws 8.8.

Accessories

	For height adjusting element size d ₂ [mm]	Dimensions of sickle spanner DIN 1810, form A [mm]	[g]	Art. No.
sickle spanner for vertical adjustment				
	25	25 – 28	45	25120.0981
	32	30 – 32	46	25120.0982
	45	45 – 50	156	25120.0983
	58	58 – 62	250	25120.0984
	70	68 – 75	253	25120.0985

Application example

EH 23050.

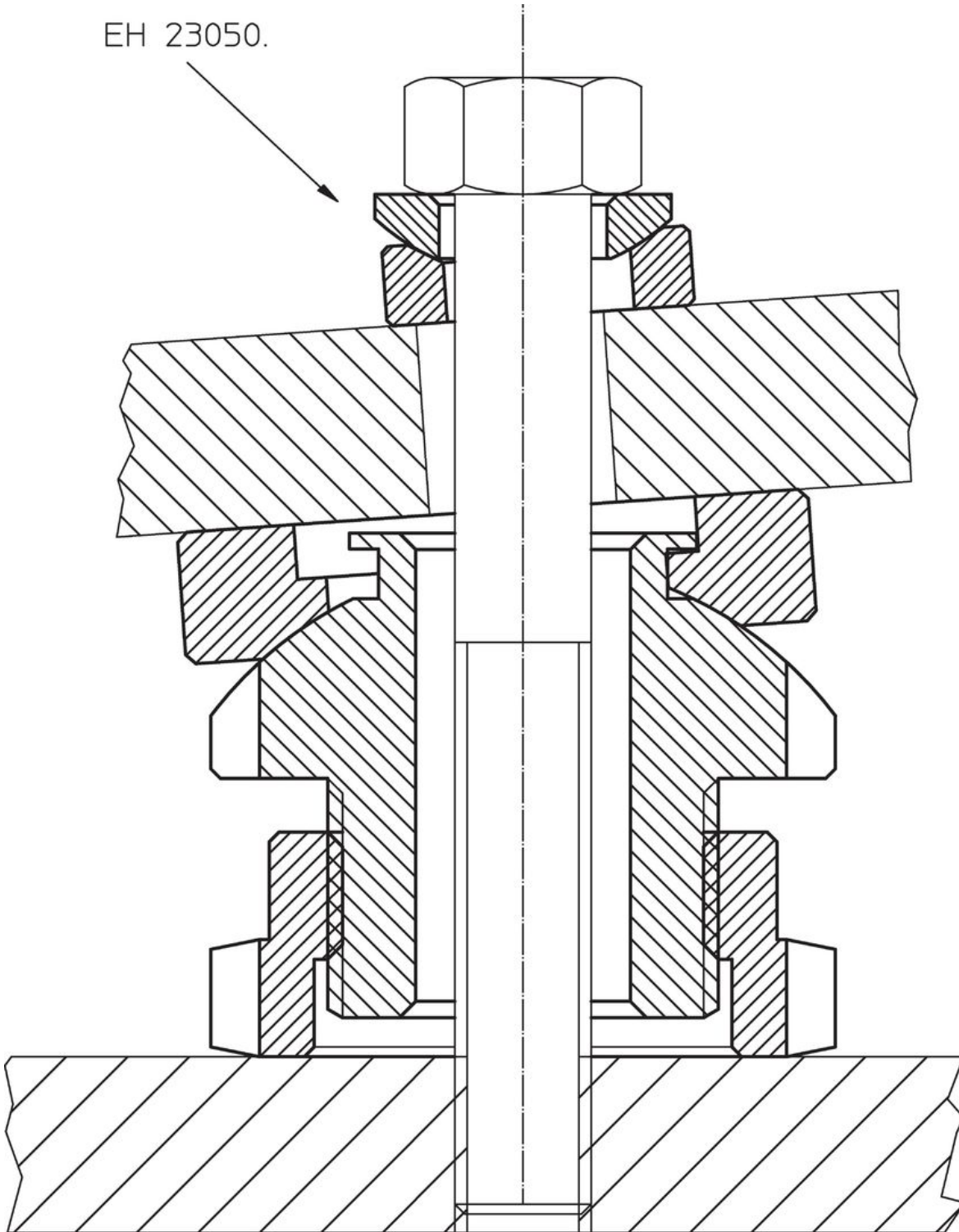

Compliance

For detailed compliance information please select the desired article number.