

Self-Aligning Pads • self-resetting

EH 22731.



Product Description

Self-aligning pads are used as stop, support and thrust pad and are suitable for installation in clamping elements.

By resetting to the parallel position the contact point of the self-aligning pad provides a defined initial position, thus preventing the pad clamping in an oblique position when inserting the workpiece.

Material

Spring element

- Thermoplastic PUR

Ball

- Ball-bearing steel, hardened, bright
- Stainless steel 1.3541, nickel-plated

Body

- Heat-treated steel, tempered, phosphated
- Stainless steel 1.4057, heat-treated

More information

Notes

Ball protected against rotating.

Loading capacity valid for steel and stainless steel designs.

Drawing

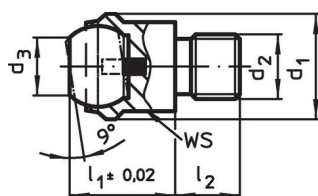

picture 1

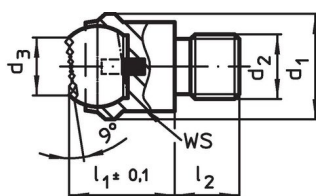

picture 2

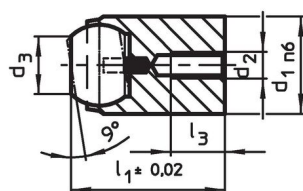

picture 3

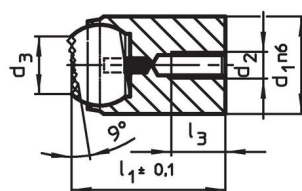

picture 4

Order information

Dimensions							Location hole		WS	Load capacity for static load max.	Tightening torque max.	[g]	Art. No.
d ₁	d ₂	d ₃	l ₁	l ₂ -0.5	l ₃ max.	Ball diameter	Ø H7	Depth min.					
[mm]								[mm]	[mm]	[kN]	[Nm]		
with male thread, flat-faced ball, bearing surface plain – picture 1, Heat-treated steel													
13	M 6	7.2	13	8	–	10	–	–	11	10	10.0	12	22731.0012
13	M 8	7.2	13	8	–	10	–	–	11	10	25.0	13	22731.0013
20	M 8	10.5	18	10	–	16	–	–	17	25	25.0	38	22731.0018
20	M10	10.5	18	10	–	16	–	–	17	25	46.0	40	22731.0019
20	M12	10.5	18	12	–	16	–	–	17	25	82.0	43	22731.0020
30	M16	20.0	27	16	–	25	–	–	27	90	206.0	149	22731.0030
50	M20	34.5	35	20	–	40	–	–	41	165	407.0	486	22731.0050
50	M24	34.5	35	24	–	40	–	–	41	165	698.0	516	22731.0060
with male thread, flat-faced ball, bearing surface plain – picture 1, Stainless steel													
13	M 6	7.2	13	8	–	10	–	–	11	10	10.0	12	22731.0112
13	M 8	7.2	13	8	–	10	–	–	11	10	25.0	13	22731.0113
20	M 8	10.5	18	10	–	16	–	–	17	25	25.0	38	22731.0118
20	M10	10.5	18	10	–	16	–	–	17	25	46.0	40	22731.0119

¹⁾ Applies only when the minimum bore depth is kept to.

d ₁	d ₂	Dimensions				Ball diameter	Location hole		WS	Load capacity for static load max.	Tightening torque max.		Art. No.
		d ₃	l ₁	l ₂ -0.5	l ₃ max.		Ø H7	Depth min.					
[mm]													
20	M12	10.5	18	12	–	16	–	–	17	25	82.0	43	22731.0120
30	M16	20.0	27	16	–	25	–	–	27	90	206.0	149	22731.0130
50	M20	34.5	35	20	–	40	–	–	41	165	407.0	486	22731.0150
50	M24	34.5	35	24	–	40	–	–	41	165	698.0	516	22731.0160
with male thread, flat-faced ball, bearing surface ribbed – picture 2, Heat-treated steel													
13	M 6	7.2	13	8	–	10	–	–	11	10	10.0	12	22731.0312
13	M 8	7.2	13	8	–	10	–	–	11	10	25.0	13	22731.0313
20	M 8	10.5	18	10	–	16	–	–	17	25	25.0	37	22731.0318
20	M10	10.5	18	10	–	16	–	–	17	25	46.0	40	22731.0319
20	M12	10.5	18	12	–	16	–	–	17	25	82.0	43	22731.0320
30	M16	20.0	27	16	–	25	–	–	27	90	206.0	149	22731.0330
50	M20	34.5	35	20	–	40	–	–	41	165	407.0	482	22731.0350
50	M24	34.5	35	24	–	40	–	–	41	165	698.0	511	22731.0360
for locating hole, flat-faced ball, bearing surface plain – picture 3, Heat-treated steel													
12 n6	M 3	7.2	17	–	3.2	10	12	12	–	10 ¹⁾	1.3	13	22731.0412
18 n6	M 4	10.5	23	–	4.0	16	18	14	–	25 ¹⁾	2.9	40	22731.0418
28 n6	M 5	20.0	34	–	6.0	25	28	22	–	90 ¹⁾	6.0	151	22731.0428
for locating hole, flat-faced ball, bearing surface plain – picture 3, Stainless steel													
12 n6	M 3	7.2	17	–	3.2	10	12	12	–	10 ¹⁾	1.3	13	22731.0452
18 n6	M 4	10.5	23	–	4.0	16	18	14	–	25 ¹⁾	2.9	40	22731.0458
28 n6	M 5	20.0	34	–	6.0	25	28	22	–	90 ¹⁾	6.0	151	22731.0468
for locating hole, flat-faced ball, bearing surface ribbed – picture 4, Heat-treated steel													
12 n6	M 3	7.2	17	–	3.2	10	12	12	–	10 ¹⁾	1.3	13	22731.0712
18 n6	M 4	10.5	23	–	4.0	16	18	14	–	25 ¹⁾	2.9	40	22731.0718
28 n6	M 5	20.0	34	–	6.0	25	28	22	–	90 ¹⁾	6.0	150	22731.0728

¹⁾ Applies only when the minimum bore depth is kept to.

Application example

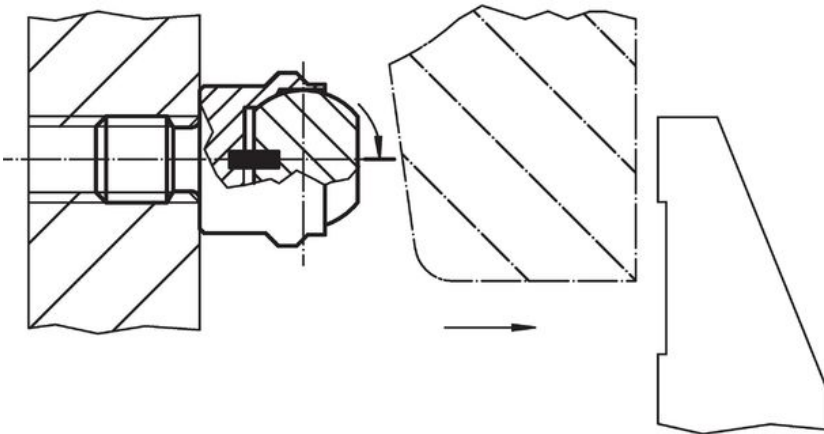
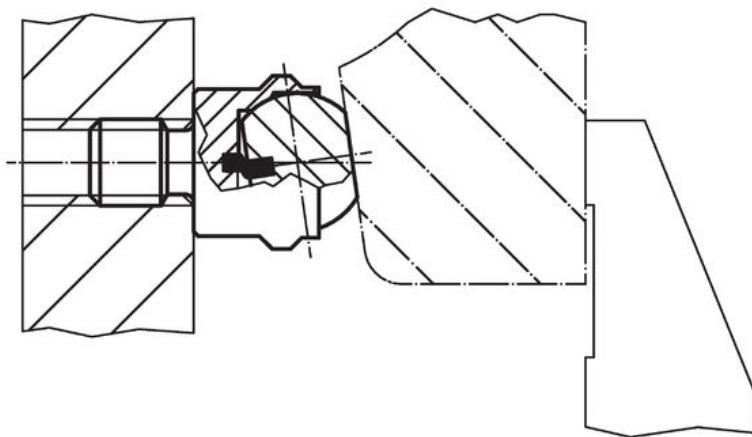
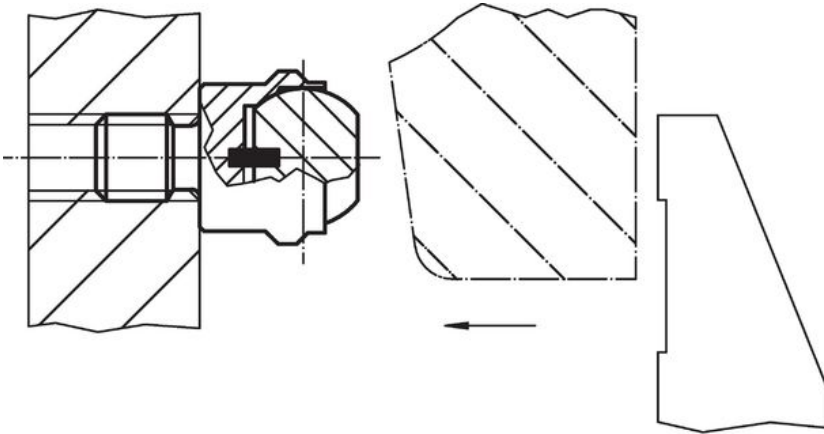

Compliance

RoHS compliant

Compliant according to Directive 2011/65/EU and Directive 2015/863.

Does not contain SVHC substances

No SVHC substances with more than 0.1% w/w contained - SVHC list [REACH] as of 27.06.2024.

Does not contain Proposition 65 substances

No Proposition 65 substances included.

<https://www.P65Warnings.ca.gov/>

Free from Conflict Minerals

This product does not contain any substances designated as "conflict minerals" such as tantalum, tin, gold or tungsten from the Democratic Republic of Congo or adjacent countries.