

## Index Plungers • without hexagon collar

EH 22120.



### Product Description

Index plungers are used for indexing bores.

### Material

#### Body

- Free cutting steel, blackened
- Stainless steel 1.4305

#### Locking pin

- Steel, hardened
- Stainless steel 1.4305, nickel-plated

#### Knob

- Thermoplastic PA 6, black

### Assembly

Suitable mounting tools are available.

### More information

### Notes

Knob not removable.  
Lock nuts have to be purchased separately.

### Further products

- Mounting Blocks, for index bolts and index plungers, die-cast
- Locating Bushings, for index bolts and index plungers
- Distance Collars, for index plungers

### Drawing

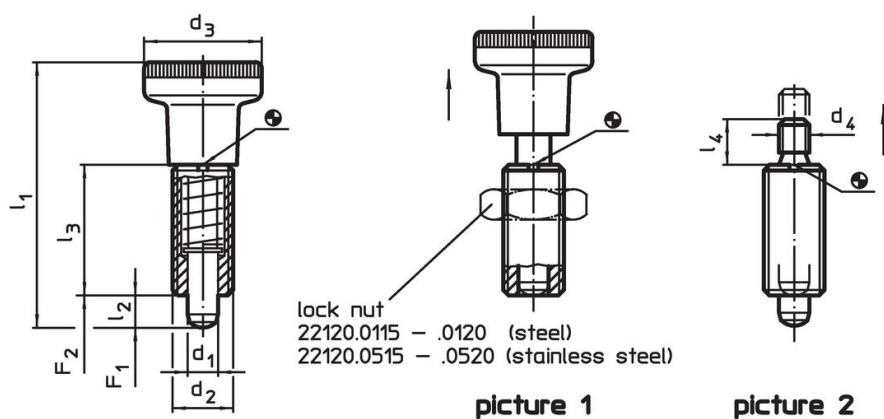

### Order information



Dimensions								Spring load <sup>1)</sup>		Temperature		Weight	Art. No.
d <sub>1</sub>	d <sub>2</sub>	d <sub>3</sub>	d <sub>4</sub>	l <sub>1</sub>	l <sub>2</sub> min.	l <sub>3</sub>	l <sub>4</sub>	F <sub>1</sub>	F <sub>2</sub>	min.	max.	[g]	
-0.02 -0.05				~				~	~				
[mm]								[N]		[°C]		[g]	
<b>with knob – picture 1, Free cutting steel</b>													
5	M10 x 1	21	–	45.0	5	22	–	6.0	14	-30	80	17	22120.0045
6	M12 x 1,5	25	–	54.5	6	26	–	6.5	19	-30	80	27	22120.0046
8	M16 x 1,5	31	–	69.0	8	34	–	11.5	28	-30	80	63	22120.0048
10	M20 x 1,5	31	–	80.0	10	41	–	23.0	54	-30	80	104	22120.0050
<b>without knob – picture 2, Free cutting steel</b>													
5	M10 x 1	–	M5	–	5	22	6	6.0	14	–	250	12	22120.0065
6	M12 x 1,5	–	M6	–	6	26	10	6.5	19	–	250	19	22120.0066
8	M16 x 1,5	–	M8	–	8	34	12	11.5	28	–	250	46	22120.0068
10	M20 x 1,5	–	M8	–	10	43	12	23.0	54	–	250	87	22120.0070
<b>with knob – picture 1, Stainless steel</b>													
5	M10 x 1	21	–	45.0	5	22	–	6.0	14	-30	80	17	22120.0445
6	M12 x 1,5	25	–	54.5	6	26	–	6.5	19	-30	80	27	22120.0446
8	M16 x 1,5	31	–	69.0	8	34	–	11.5	28	-30	80	63	22120.0448
10	M20 x 1,5	31	–	80.0	10	41	–	23.0	54	-30	80	104	22120.0450

<sup>1)</sup> statistical average value

Dimensions								Spring load <sup>1)</sup>		min. max.			Art. No.	
d <sub>1</sub>	d <sub>2</sub>	d <sub>3</sub>	d <sub>4</sub>	l <sub>1</sub>	l <sub>2</sub>	l <sub>3</sub>	l <sub>4</sub>	F <sub>1</sub>	F <sub>2</sub>	min.	max.	[g]		
-0.02				~	min.			~	~					
-0.05														
[mm]														
[N]														
[°C]														
<b>without knob – picture 2, Stainless steel</b>														
5	M10 x 1	–	M5	–	5	22	6	6.0	14	–	250	12	<a href="#">22120.0465</a>	
6	M12 x 1,5	–	M6	–	6	26	10	6.5	19	–	250	19	<a href="#">22120.0466</a>	
8	M16 x 1,5	–	M8	–	8	34	12	11.5	28	–	250	46	<a href="#">22120.0468</a>	
10	M20 x 1,5	–	M8	–	10	43	12	23.0	54	–	250	87	<a href="#">22120.0470</a>	

<sup>1)</sup> statistical average value

### Accessories

	Dimensions d <sub>2</sub> [mm]	Wrench size [mm]		Art. No.
<b>Lock nuts ISO 8675 (DIN 439), Steel</b>				
	M10 x 1	16	5.2	<a href="#">22120.0115</a>
	M12 x 1,5	18	7.5	<a href="#">22120.0116</a>
	M16 x 1,5	24	15.0	<a href="#">22120.0118</a>
	M20 x 1,5	30	32.0	<a href="#">22120.0120</a>
<b>Lock nuts ISO 8675 (DIN 439), Stainless steel</b>				
	M10 x 1	16	5.2	<a href="#">22120.0515</a>
	M12 x 1,5	18	7.5	<a href="#">22120.0516</a>
	M16 x 1,5	24	15.0	<a href="#">22120.0518</a>
	M20 x 1,5	30	32.0	<a href="#">22120.0520</a>
<b>assembly tool, Steel</b>				
	M10 x 1	–	9.3	<a href="#">22120.0955</a>
	M12 x 1,5	–	14.0	<a href="#">22120.0956</a>
	M16 x 1,5	–	25.0	<a href="#">22120.0958</a>
	M20 x 1,5	–	27.0	<a href="#">22120.0960</a>

### Application example

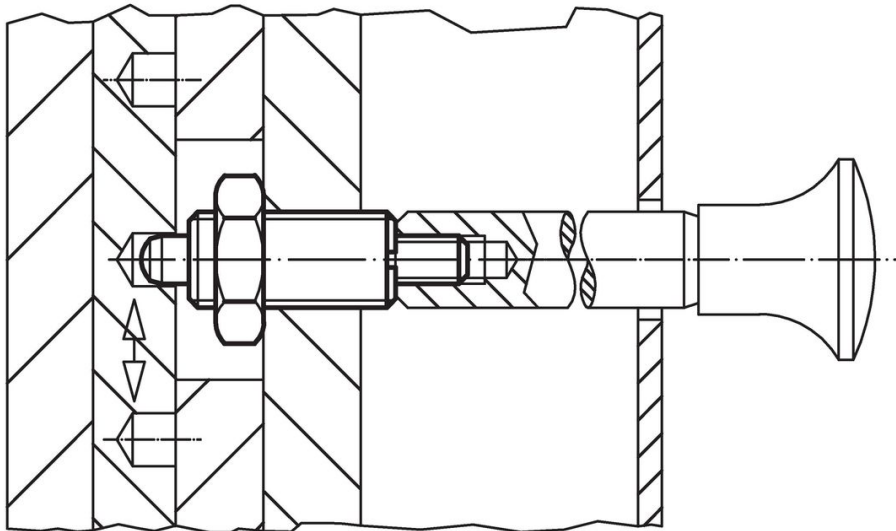

### Compliance

For detailed compliance information please select the desired article number.