

Mounting Blocks · for index bolts and index plungers, die-cast

EH 22110.



Product Description

Assembly support and extended application for index bolts and index plungers. Can also be used for locating the locating bushings and positioning bushings EH 22110..

Material

Grub Screw

- Steel, blackened, with brass pad

Body

- Zinc die-cast, plastic coated, black

Assembly

The countersink (t / d4) in the thread d₁ is one-sided.

More information

Further products

- Locating Bushings, for index bolts and index plungers
- Positioning Bushings, for index bolts and index plungers

Drawing

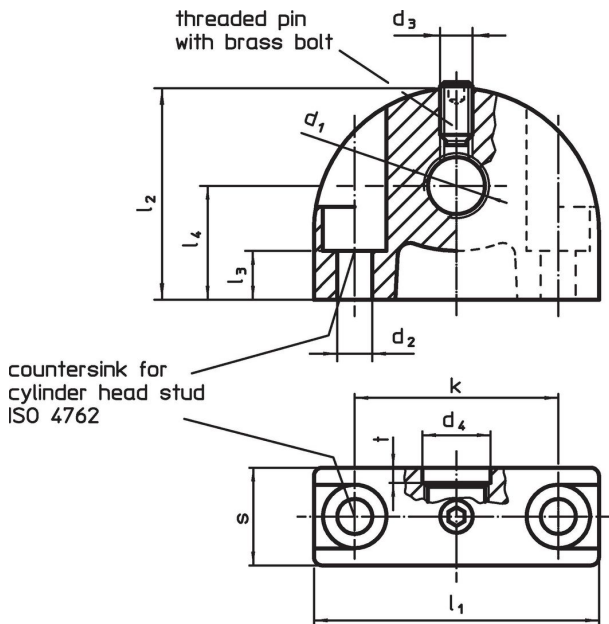

Order information

Dimensions												max. [°C]	[g]	Art. No.		
d ₁	d ₂	d ₃	d ₄	k	l ₁	l ₂	l ₃	l ₄	s	t	[mm]					
mounting hole vertical to index bolt and index plunger																
M 8 x 1	4.3	M4	8.2	25	35	26	11.5	14	12	2	100	39	22110.0408			
M 8	4.3	M4	8.2	25	35	26	6.0	14	12	2	100	40	22110.0508			
M10 x 1	4.3	M4	10.2	25	35	26	11.5	14	12	2	100	36	22110.0410			
M10	4.3	M4	10.2	25	35	26	6.0	14	12	2	100	38	22110.0510			
M12 x 1,5	4.3	M4	12.2	25	35	26	11.5	14	12	3	100	41	22110.0412			
M12	4.3	M4	12.2	25	35	26	6.0	14	12	3	100	36	22110.0512			
M16 x 1,5	5.3	M5	16.2	35	47	34	15.5	18	14	3	100	77	22110.0416			
M16	5.3	M5	16.2	35	47	34	10.0	18	14	3	100	78	22110.0516			
M20 x 1,5	5.3	M5	20.2	35	47	34	15.5	18	14	3	100	68	22110.0420			

Application example



Compliance

For detailed compliance information please select the desired article number.