

Index Plungers · with mounting flange, horizontal EH 22110.



Product Description

Index plungers are used for indexing bores.

Material

Housing

- Zinc die-cast, plastic coated, black

Locking pin

- Stainless steel 1.4305

Knob

- Thermoplastic PA 6, black, dull

Pull-ring

- Stainless steel 1.4310

Assembly

Assembly by means of washers ISO 7092.

Operation

When using locking index plungers, the knob is pulled-out, turned 90° and secured by a notched catch (when locking pin should not overhang).

More information

Notes

Knob not removable.

Drawing

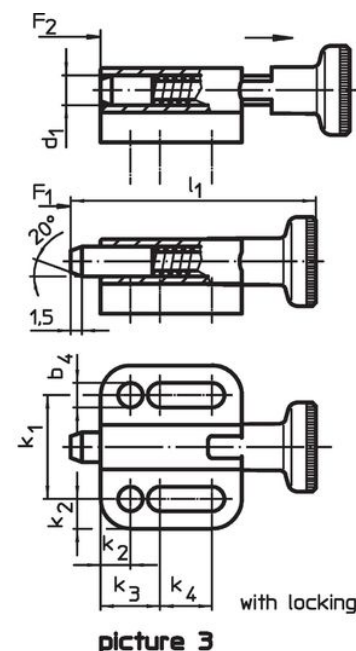
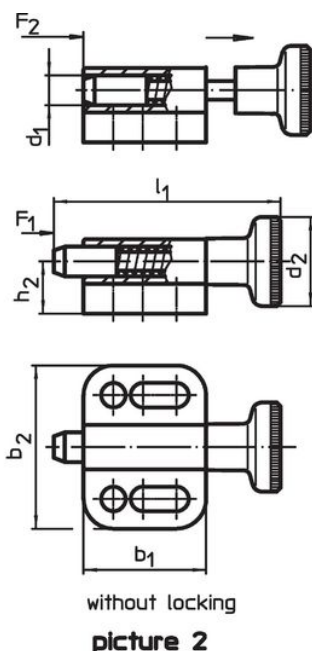
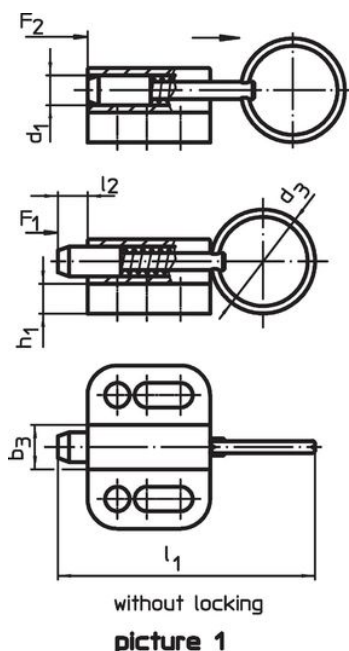

Order information

Dimensions															Spring load ¹⁾		Temperature		Weight [g]	Art. No.
d ₁ h11	d ₂	d ₃	b ₁	b ₂	b ₃	b ₄ -0.2	h ₁	h ₂	k ₁ ±0.05	k ₂	k ₃	k ₄	l ₁	l ₂ min.	F ₁ ~	F ₂ ~	min.	max.		
with pull-ring, without locking – picture 1																				
4	–	14	16.5	22	6.0	3.3	4.0	7.0	14	4.0	8	4.5	34.5	4	3	12	–	100	11	22110.0304
5	–	18	22.0	28	8.0	4.3	4.5	9.5	18	5.0	10	7.0	45.0	5	5	24	–	100	21	22110.0305
6	–	24	27.5	32	10.0	5.4	5.0	10.5	21	5.5	12	10.0	57.5	6	5	21	–	100	40	22110.0306
8	–	30	33.0	34	12.0	5.4	6.0	12.5	23	5.5	12	15.5	71.0	8	6	22	–	100	58	22110.0308
10	–	30	35.0	39	14.5	6.5	6.0	14.5	27	6.0	15	13.5	75.0	10	4	25	–	100	83	22110.0310
with knob, without locking – picture 2																				
4	12	–	16.5	22	6.0	3.3	4.0	7.0	14	4.0	8	4.5	30.5	4	3	12	-30	80	11	22110.0324
5	16	–	22.0	28	8.0	4.3	4.5	9.5	18	5.0	10	7.0	40.0	5	5	24	-30	80	20	22110.0325
6	18	–	27.5	32	10.0	5.4	5.0	10.5	21	5.5	12	10.0	49.0	6	5	21	-30	80	37	22110.0326
8	21	–	33.0	34	12.0	5.4	6.0	12.5	23	5.5	12	15.5	59.0	8	6	22	-30	80	59	22110.0328
10	25	–	35.0	39	14.5	6.5	6.0	14.5	27	6.0	15	13.5	67.5	10	4	25	-30	80	90	22110.0330

¹⁾ statistical average value

Dimensions															Spring load ¹⁾		Temperature		Weight [g]	Art. No.				
d ₁ h11	d ₂	d ₃	b ₁	b ₂	b ₃	b ₄ -0.2	h ₁	h ₂	k ₁ ±0.05	k ₂	k ₃	k ₄	l ₁	l ₂ min.	F ₁ ~	F ₂ ~	min.	max.			[°C]	[g]		
[mm]																				[N]	[°C]	[g]		
with knob and locking – picture 3																								
4	12	-	19.0	22	6.0	3.3	4.0	7.0	14	4.0	8	7.0	33.0	4	3	12	-30	80	12	22110.0344				
5	16	-	25.5	28	8.0	4.3	4.5	9.5	18	5.0	10	10.5	43.5	5	5	24	-30	80	26	22110.0345				
6	18	-	30.5	32	10.0	5.4	5.0	10.5	21	5.5	12	13.0	52.0	6	5	21	-30	80	40	22110.0346				
8	21	-	37.5	34	12.0	5.4	6.0	12.5	23	5.5	12	20.0	63.5	8	6	22	-30	80	67	22110.0348				
10	25	-	40.0	39	14.5	6.5	6.0	14.5	27	6.0	15	18.5	72.5	10	4	25	-30	80	98	22110.0350				

¹⁾ statistical average value

Application example

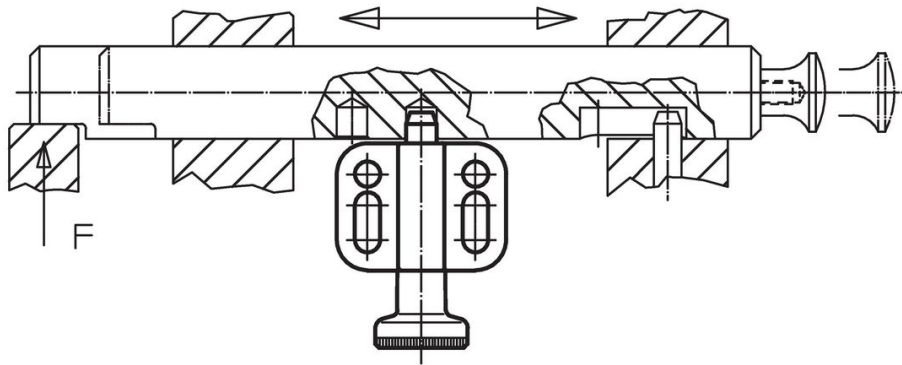

Compliance

RoHS compliant

Compliant according to Directive 2011/65/EU and Directive 2015/863.

Does not contain SVHC substances

No SVHC substances with more than 0.1% w/w contained - SVHC list [REACH] as of 27.06.2024.

Does not contain Proposition 65 substances

No Proposition 65 substances included.

<https://www.P65Warnings.ca.gov/>

Free from Conflict Minerals

This product does not contain any substances designated as "conflict minerals" such as tantalum, tin, gold or tungsten from the Democratic Republic of Congo or adjacent countries.