

Index Plungers Compact • with hexagon collar

EH 22110.

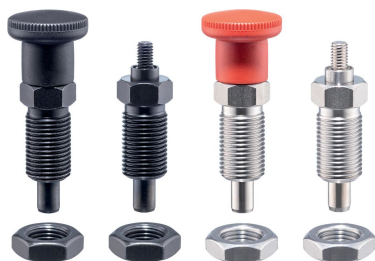

Product Description

Index plungers are used for indexing bores.
Types with / without lock have the same building height.
Due to a thread recess the index plungers can be completely screwed in.

Material

Body

- Steel, blackened
- Stainless steel 1.4305

Locking pin

- Steel, hardened
- Stainless steel 1.4305, nickel-plated

Knob

- Thermoplastic PA 6, black, dull
- Thermoplast PA 6, red, dull

Assembly

The screw length can be adapted by distance collars for index plungers (EH 22120.).

More information

Notes

Knob not removable.
Lock nuts have to be purchased separately.

Further products

- Mounting Blocks, for index bolts and index plungers, die-cast
- Locating Bushings, for index bolts and index plungers
- Distance Collars, for index plungers

Drawing

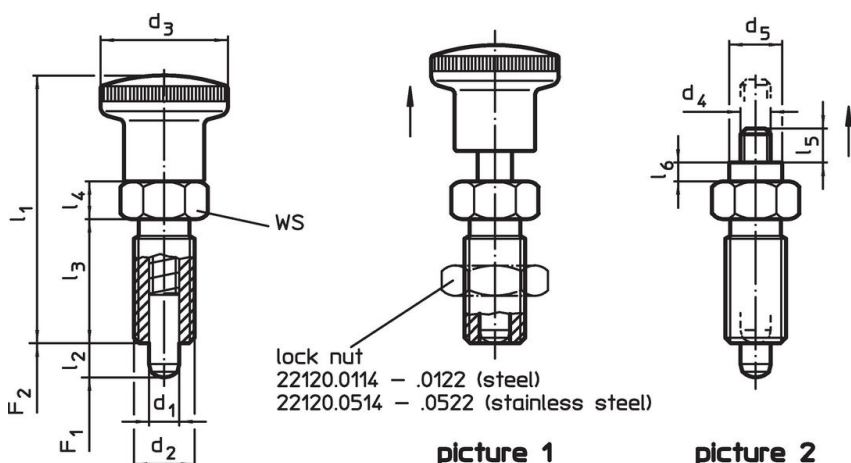

Order information

Dimensions											WS	Spring load ¹⁾		Temperature		Weight	Art. No.
d ₁	d ₂	l ₂ min.	d ₃	d ₄	d ₅	l ₁	l ₃	l ₄	l ₅	l ₆		F ₁ ~	F ₂ ~	min.	max.		
[mm]											[mm]	[N]		[°C]		[g]	
with knob, black – picture 1, Steel																	
4	M 8 x 1	4	16	-	-	35.0	16	5	-	-	10	4.5	12.0	-30	80	10	22110.0103
4	M 8 x 1	6	16	-	-	35.0	16	5	-	-	10	4.0	12.5	-30	80	10	22110.0104
5	M10 x 1	5	19	-	-	40.0	18	6	-	-	12	5.0	15.0	-30	80	18	22110.0106
5	M10 x 1	8	19	-	-	40.0	18	6	-	-	12	5.0	18.0	-30	80	18	22110.0107
6	M12 x 1,5	6	23	-	-	48.0	22	6	-	-	14	6.5	19.0	-30	80	29	22110.0109
6	M12 x 1,5	9	23	-	-	48.0	22	6	-	-	14	6.0	25.0	-30	80	29	22110.0110
8	M16 x 1,5	8	28	-	-	58.0	26	8	-	-	17	8.5	26.0	-30	80	62	22110.0112
8	M16 x 1,5	12	28	-	-	58.0	26	8	-	-	17	8.5	28.0	-30	80	62	22110.0113
10	M16 x 1,5	12	28	-	-	58.0	26	8	-	-	17	9.5	38.0	-30	80	63	22110.0115
12	M20 x 1,5	15	33	-	-	67.0	33	10	-	-	22	11.5	40.0	-30	80	128	22110.0116
16	M24 x 2	20	33	-	-	78.5	38	12	-	-	27	13.0	54.0	-30	80	203	22110.0117

¹⁾ statistical average value



d ₁ -0.02 -0.05	d ₂	l ₂ min.	Dimensions									WS [mm]	Spring load ¹⁾		min. max. [°C]		[g]	Art. No.
			d ₃	d ₄	d ₅	l ₁	l ₃	l ₄	l ₅	l ₆	F ₁ ~		F ₂ ~	[N]		[g]		
with knob, red – picture 1, Steel																		
4	M 8 x 1	4	16	-	-	35.0	16	5	-	-	10	4.5	12.0	-30	80	10	22110.2103	
4	M 8 x 1	6	16	-	-	35.0	16	5	-	-	10	4.0	12.5	-30	80	11	22110.2104	
5	M10 x 1	5	19	-	-	40.0	18	6	-	-	12	5.0	15.0	-30	80	18	22110.2106	
5	M10 x 1	8	19	-	-	40.0	18	6	-	-	12	5.0	18.0	-30	80	18	22110.2107	
6	M12 x 1,5	6	23	-	-	48.0	22	6	-	-	14	6.5	19.0	-30	80	30	22110.2109	
6	M12 x 1,5	9	23	-	-	48.0	22	6	-	-	14	6.0	25.0	-30	80	29	22110.2110	
8	M16 x 1,5	8	28	-	-	58.0	26	8	-	-	17	8.5	26.0	-30	80	62	22110.2112	
8	M16 x 1,5	12	28	-	-	58.0	26	8	-	-	17	8.5	28.0	-30	80	64	22110.2113	
10	M16 x 1,5	12	28	-	-	58.0	26	8	-	-	17	9.5	38.0	-30	80	65	22110.2115	
12	M20 x 1,5	15	33	-	-	71.5	33	10	-	-	22	11.5	40.0	-30	80	117	22110.2116	
16	M24 x 2	20	33	-	-	78.5	38	12	-	-	27	13.0	54.0	-30	80	202	22110.2117	
without knob – picture 2, Steel																		
4	M 8 x 1	4	-	M3	7	-	16	5	4.5	2.5	10	4.5	12.0	-	250	9	22110.0143	
4	M 8 x 1	6	-	M3	7	-	16	5	4.5	2.5	10	4.0	12.5	-	250	9	22110.0144	
5	M10 x 1	5	-	M4	8	-	18	6	5.5	3.0	12	5.0	15.0	-	250	16	22110.0146	
5	M10 x 1	8	-	M4	8	-	18	6	5.5	3.0	12	5.0	18.0	-	250	17	22110.0147	
6	M12 x 1,5	6	-	M5	9	-	22	6	7.0	3.5	14	6.5	19.0	-	250	25	22110.0149	
6	M12 x 1,5	9	-	M5	9	-	22	6	7.0	3.5	14	6.0	25.0	-	250	26	22110.0150	
8	M16 x 1,5	8	-	M6	10	-	26	8	8.5	4.0	17	8.5	26.0	-	250	54	22110.0152	
8	M16 x 1,5	12	-	M6	10	-	26	8	8.5	4.0	17	8.5	28.0	-	250	55	22110.0153	
10	M16 x 1,5	12	-	M6	10	-	26	8	8.5	4.0	17	9.5	38.0	-	250	56	22110.0155	
12	M20 x 1,5	15	-	M6	12	-	33	10	8.5	4.0	22	11.5	40.0	-	250	111	22110.0156	
16	M24 x 2	20	-	M8	15	-	38	12	11.5	5.0	27	13.0	54.0	-	250	193	22110.0157	
with knob, black – picture 1, Stainless steel																		
4	M 8 x 1	4	16	-	-	35.0	16	5	-	-	10	4.5	12.0	-30	80	10	22110.0203	
4	M 8 x 1	6	16	-	-	35.0	16	5	-	-	10	4.0	12.5	-30	80	10	22110.0204	
5	M10 x 1	5	19	-	-	40.0	18	6	-	-	12	5.0	15.0	-30	80	18	22110.0206	
5	M10 x 1	8	19	-	-	40.0	18	6	-	-	12	5.0	18.0	-30	80	18	22110.0207	
6	M12 x 1,5	6	23	-	-	48.0	22	6	-	-	14	6.5	19.0	-30	80	29	22110.0209	
6	M12 x 1,5	9	23	-	-	48.0	22	6	-	-	14	6.0	25.0	-30	80	29	22110.0210	
8	M16 x 1,5	8	28	-	-	58.0	26	8	-	-	17	8.5	26.0	-30	80	62	22110.0212	
8	M16 x 1,5	12	28	-	-	58.0	26	8	-	-	17	8.5	28.0	-30	80	62	22110.0213	
10	M16 x 1,5	12	28	-	-	58.0	26	8	-	-	17	9.5	38.0	-30	80	63	22110.0215	
12	M20 x 1,5	15	33	-	-	67.0	33	10	-	-	22	11.5	40.0	-30	80	128	22110.0216	
16	M24 x 2	20	33	-	-	78.5	38	12	-	-	27	13.0	54.0	-30	80	203	22110.0217	
with knob, red – picture 1, Stainless steel																		
4	M 8 x 1	4	16	-	-	35.0	16	5	-	-	10	4.5	12.0	-30	80	10	22110.2203	
4	M 8 x 1	6	16	-	-	35.0	16	5	-	-	10	4.0	12.5	-30	80	11	22110.2204	
5	M10 x 1	5	19	-	-	40.0	18	6	-	-	12	5.0	15.0	-30	80	18	22110.2206	
5	M10 x 1	8	19	-	-	40.0	18	6	-	-	12	5.0	18.0	-30	80	18	22110.2207	
6	M12 x 1,5	6	23	-	-	48.0	22	6	-	-	14	6.5	19.0	-30	80	30	22110.2209	
6	M12 x 1,5	9	23	-	-	48.0	22	6	-	-	14	6.0	25.0	-30	80	29	22110.2210	
8	M16 x 1,5	8	28	-	-	58.0	26	8	-	-	17	8.5	26.0	-30	80	62	22110.2212	
8	M16 x 1,5	12	28	-	-	58.0	26	8	-	-	17	8.5	28.0	-30	80	64	22110.2213	
10	M16 x 1,5	12	28	-	-	58.0	26	8	-	-	17	9.5	38.0	-30	80	65	22110.2215	
12	M20 x 1,5	15	33	-	-	71.5	33	10	-	-	22	11.5	40.0	-30	80	117	22110.2216	
16	M24 x 2	20	33	-	-	78.5	38	12	-	-	27	13.0	54.0	-30	80	202	22110.2217	
without knob – picture 2, Stainless steel																		
4	M 8 x 1	4	-	M3	7	-	16	5	4.5	2.5	10	4.5	12.0	-	250	9	22110.0243	
4	M 8 x 1	6	-	M3	7	-	16	5	4.5	2.5	10	4.0	12.5	-	250	9	22110.0244	
5	M10 x 1	5	-	M4	8	-	18	6	5.5	3.0	12	5.0	15.0	-	250	16	22110.0246	
5	M10 x 1	8	-	M4	8	-	18	6	5.5	3.0	12	5.0	18.0	-	250	17	22110.0247	
6	M12 x 1,5	6	-	M5	9	-	22	6	7.0	3.5	14	6.5	19.0	-	250	25	22110.0249	
6	M12 x 1,5	9	-	M5	9	-	22	6	7.0	3.5	14	6.0	25.0	-	250	26	22110.0250	
8	M16 x 1,5	8	-	M6	10	-	26	8	8.5	4.0	17	8.5	26.0	-	250	54	22110.0252	

¹⁾ statistical average value

d ₁ -0.02 -0.05	d ₂	l ₂ min.	Dimensions								WS [mm]	Spring load ¹⁾		min. max.		[g]	Art. No.
			d ₃	d ₄	d ₅	l ₁	l ₃	l ₄	l ₅	l ₆		F ₁ ~	F ₂ ~	[°C]			
			[mm]									[N]					
8	M16 x 1,5	12	-	M6	10	-	26	8	8.5	4.0	17	8.5	28.0	-	250	55	22110.0253
10	M16 x 1,5	12	-	M6	10	-	26	8	8.5	4.0	17	9.5	38.0	-	250	56	22110.0255
12	M20 x 1,5	15	-	M6	12	-	33	10	8.5	4.0	22	11.5	40.0	-	250	111	22110.0256
16	M24 x 2	20	-	M8	15	-	38	12	11.5	5.0	27	13.0	54.0	-	250	193	22110.0257

¹⁾ statistical average value

Accessories

	Dimensions		Wrench size		[g]	Art. No.
	d ₂ [mm]		[mm]			
Lock nuts ISO 8675 (DIN 439), Steel						
	M 8 x 1		13		2.7	22120.0114
	M10 x 1		16		5.2	22120.0115
	M12 x 1,5		18		7.5	22120.0116
	M16 x 1,5		24		15.0	22120.0118
	M20 x 1,5		30		32.0	22120.0120
	M24 x 2		36		58.0	22120.0122
Lock nuts ISO 8675 (DIN 439), Stainless steel						
	M 8 x 1		13		2.7	22120.0514
	M10 x 1		16		5.2	22120.0515
	M12 x 1,5		18		7.5	22120.0516
	M16 x 1,5		24		15.0	22120.0518
	M20 x 1,5		30		32.0	22120.0520
	M24 x 2		36		58.0	22120.0522

Application example

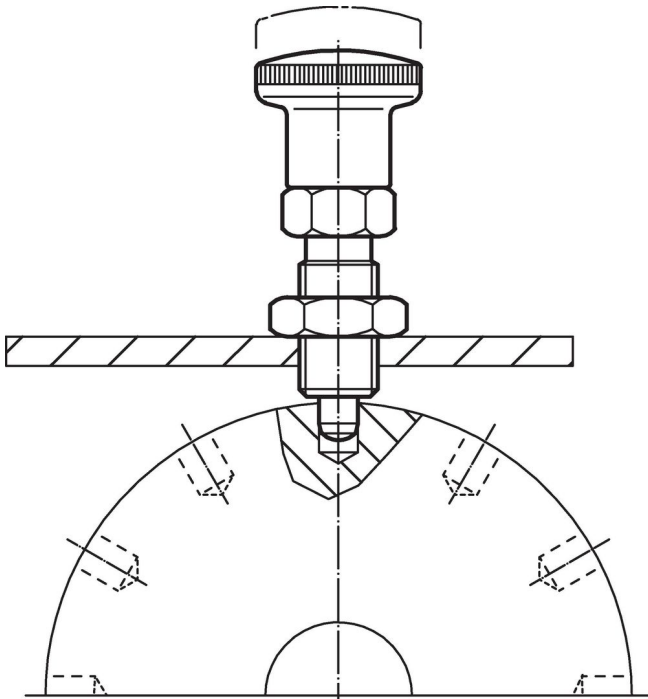

Compliance

For detailed compliance information please select the desired article number.