

Spring Plungers · smooth, with collar and ball EH 22080.



Product Description

Spring plungers can be used for locating or for applying pressure, as a detent or for ejection.

Material

Body

- Stainless steel 1.4303
- Brass
- Thermoplastic POM, blue

Ball

- Stainless steel, hardened
- Thermoplastic POM, white

Spring

- Stainless steel

Assembly

A tolerance of H7 is recommended for the locating hole of d_1 .

Characteristic

Light spring load: marked with one line
Standard spring load: no marking
Heavy spring load: marked with two lines

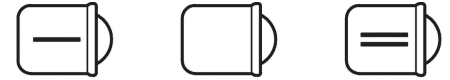

Light spring load

Standard spring load

Heavy spring load

More information

Notes

Special types on request.

Spring plungers are specially tested for spring range and forces.

References

Calculation of indexing resistance, please refer to appendix - Technical Data - Version with higher spring forces see "EH 22080. Spring Plungers, smooth, long, with collar and ball".

Further products

- Spring Plungers, with collar and ball, front slot
- Spring Plungers, smooth, long, with collar and ball
- Spring Plungers, smooth, with collar and ball, self-clamping
- Locators, with bore hole, for spring plungers
- Locators, smooth, for spring plungers
- Holders, for spring plungers

Drawing

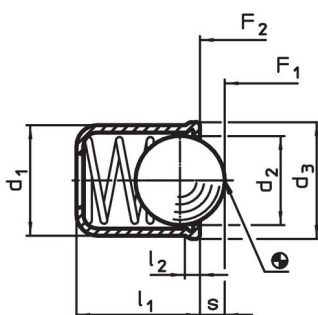

picture 1

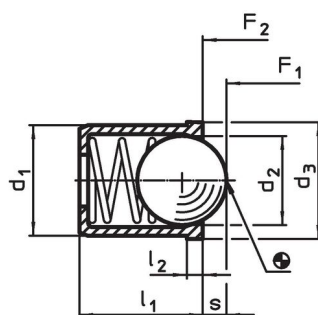

picture 2

Order information

d ₁ +0.1	Dimensions				Stroke s [mm]	Spring load ¹⁾		min. max. [°C]		Location hole H7 [mm]	[g]	Art. No.
	d ₂	d ₃	l ₁	l ₂ ~		F ₁ ~	F ₂ ~	[N]				
body and ball from stainless steel, light spring load – picture 1												
3	2.38	3.5	4.0	0.6	0.70	0.4	1.3	–	250	3	0.1	22080.1003
4	3.00	4.6	5.0	0.9	1.00	0.4	1.0	–	250	4	0.3	22080.1004
5	4.00	5.6	6.0	0.9	1.40	0.5	4.7	–	250	5	0.6	22080.1005
6	5.00	6.5	7.0	1.0	1.80	2.3	6.5	–	250	6	1.0	22080.1006
8	6.50	8.5	9.0	1.1	2.40	4.0	9.0	–	250	8	2.0	22080.1008
10	8.50	11.0	13.0	1.5	3.30	3.9	10.0	–	250	10	4.0	22080.1010
12	10.00	13.0	16.0	2.3	4.00	6.2	14.6	–	250	12	7.0	22080.1012
body and ball from stainless steel, standard spring load – picture 1												
3	2.38	3.5	4.0	0.6	0.70	1.8	3.5	–	250	3	0.1	22080.0003
4	3.00	4.6	5.0	0.9	1.00	2.5	6.0	–	250	4	0.3	22080.0004
5	4.00	5.6	6.0	0.9	1.40	3.0	6.5	–	250	5	0.6	22080.0005
6	5.00	6.5	7.0	1.0	1.80	5.5	11.5	–	250	6	1.0	22080.0006
8	6.50	8.5	9.0	1.1	2.40	7.0	12.5	–	250	8	2.1	22080.0008
10	8.50	11.0	13.0	1.5	3.30	8.5	18.5	–	250	10	4.5	22080.0010
12	10.00	13.0	16.0	2.3	4.00	12.0	26.5	–	250	12	7.2	22080.0012
body and ball from stainless steel, heavy spring load – picture 1												
3	2.38	3.5	4.0	0.6	0.70	2.4	5.5	–	250	3	0.1	22080.2003
4	3.00	4.6	5.0	0.9	1.00	5.0	10.4	–	250	4	0.3	22080.2004
5	4.00	5.6	6.0	0.9	1.40	6.0	12.0	–	250	5	0.6	22080.2005
6	5.00	6.5	7.0	1.0	1.80	7.3	19.0	–	250	6	1.0	22080.2006
8	6.50	8.5	9.0	1.1	2.40	11.0	25.0	–	250	8	2.2	22080.2008
10	8.50	11.0	13.0	1.5	3.30	17.0	37.0	–	250	10	4.6	22080.2010
12	10.00	13.0	16.0	2.3	4.00	28.0	57.0	–	250	12	7.4	22080.2012
body from brass, ball from stainless steel, standard spring load – picture 2												
3	2.38	3.6	4.0	0.6	0.60	1.8	3.5	–	250	3	0.2	22080.0203
4	3.00	4.5	5.0	1.0	0.80	3.0	6.0	–	250	4	0.4	22080.0204
5	4.00	5.5	6.0	1.0	1.00	4.0	6.5	–	250	5	0.7	22080.0205
6	5.00	6.5	7.0	1.0	1.60	6.0	11.5	–	250	6	1.2	22080.0206
8	6.50	8.5	9.0	1.0	1.90	8.0	12.5	–	250	8	2.8	22080.0208
body from thermoplastic, ball from stainless steel, standard spring load – picture 2												
3	2.00	3.6	4.0	0.6	0.55	1.7	3.5	-30	50	3	0.1	22080.0403
4	3.00	4.6	5.0	1.0	0.80	3.0	6.5	-30	50	4	0.2	22080.0404
5	4.00	5.6	6.0	1.0	1.00	6.0	9.4	-30	50	5	0.4	22080.0405
6	5.00	6.5	7.0	1.0	1.60	6.2	12.6	-30	50	6	0.7	22080.0406
8	6.50	8.5	9.0	1.0	1.90	10.0	20.4	-30	50	8	1.5	22080.0408
10	8.00	11.0	13.5	1.5	2.40	11.9	22.3	-30	50	10	3.1	22080.0410
12	10.00	13.0	16.0	1.5	3.30	14.0	25.0	-30	50	12	5.7	22080.0412
body and ball from thermoplastic, standard spring load – picture 2												
4	3.00	4.6	5.0	1.0	0.80	3.0	6.5	-30	50	4	0.1	22080.0604
5	4.00	5.6	6.0	1.0	1.00	6.0	9.4	-30	50	5	0.2	22080.0605
6	5.00	6.5	7.0	1.0	1.60	6.2	12.6	-30	50	6	0.3	22080.0606
8	6.50	8.5	9.0	1.0	1.90	10.0	20.4	-30	50	8	0.6	22080.0608
10	8.00	11.0	13.5	1.5	2.40	11.9	22.3	-30	50	10	1.4	22080.0610
12	10.00	13.0	16.0	1.5	3.30	14.0	25.0	-30	50	12	2.4	22080.0612

¹⁾ statistical average value

Application example

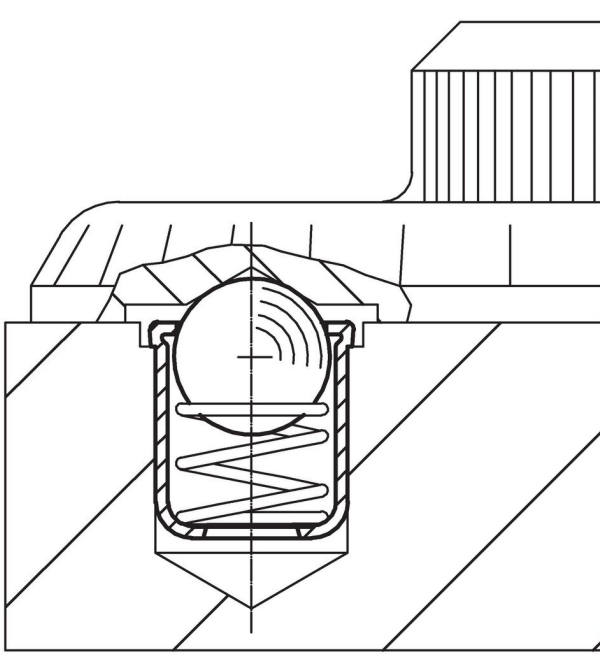

Compliance

For detailed compliance information please select the desired article number.