

## Spring Plungers · with ball and internal hexagon EH 22030.



### Product Description

Spring plungers can be used for locating or for applying pressure, as a detent or for ejection.

#### Material

##### Body

- Free cutting steel, blackened
- Stainless steel 1.4305

##### Ball

- Ball-bearing steel, hardened
- Stainless steel, hardened

##### Spring

- Stainless steel

#### Characteristic

Standard spring load: no marking

Heavy spring load: marked with two lines

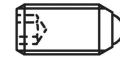

Standard spring load

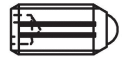

Heavy spring load

#### More information

#### Notes

Special types on request.

Spring plungers are specially tested for spring range and forces.

#### References

Thread lock on request, please refer to appendix - Technical Data -  
Calculation of indexing resistance, please refer to appendix - Technical Data -

#### Further products

- Locators, with bore hole, for spring plungers
- Locators, smooth, for spring plungers
- Holders, for spring plungers

### Drawing

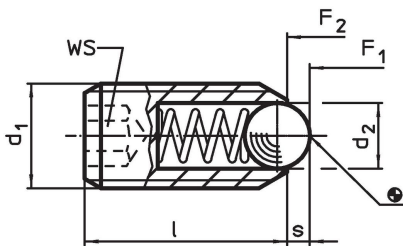

### Order information

Dimensions			WS [mm]	Stroke s [mm]	Spring load <sup>1)</sup>		max. [°C]	[g]	Art. No.
d <sub>1</sub>	d <sub>2</sub>	l			F <sub>1</sub>	F <sub>2</sub>			
[mm]			[mm]	[mm]	[N]	[N]	[°C]	[g]	
<b>free cutting steel, standard spring load</b>									
M 3	1.5	8	1.5	0.4	3.0	4.5	250	0.2	22030.0003
M 4	2.5	12	2.0	0.8	8.5	14.0	250	0.6	22030.0004
M 5	3.0	14	2.5	0.9	8.0	14.0	250	1.2	22030.0005
M 6	3.5	15	3.0	1.0	11.0	18.0	250	1.7	22030.0006
M 8	4.5	18	4.0	1.5	18.0	31.0	250	3.9	22030.0008
M10	6.0	23	5.0	2.0	24.0	45.0	250	8.0	22030.0010
M12	8.0	26	6.0	2.5	26.0	49.0	250	13.0	22030.0012
M16	10.0	33	8.0	3.5	41.0	86.0	250	32.0	22030.0016
M20	12.0	43	10.0	4.5	56.0	111.0	250	67.0	22030.0020
M24	15.0	48	12.0	5.5	81.0	151.0	250	105.0	22030.0024
<b>free cutting steel, heavy spring load</b>									
M 3	1.5	8	1.5	0.4	5.0	9.0	250	0.3	22030.0043
M 4	2.5	12	2.0	0.8	12.0	18.0	250	0.6	22030.0044
M 5	3.0	14	2.5	0.9	15.0	22.0	250	1.2	22030.0045

<sup>1)</sup> statistical average value

d <sub>1</sub>	Dimensions		WS [mm]	Stroke s [mm]	Spring load <sup>1)</sup>		max. [°C]	[g]	Art. No.
	d <sub>2</sub> [mm]	l			F <sub>1</sub> ~ [N]	F <sub>2</sub> ~ [N]			
M 6	3.5	15	3.0	1.0	19.0	28.0	250	1.7	22030.0046
M 8	4.5	18	4.0	1.5	36.0	62.0	250	4.0	22030.0048
M10	6.0	23	5.0	2.0	57.0	104.0	250	8.2	22030.0050
M12	8.0	26	6.0	2.5	61.0	110.0	250	13.0	22030.0052
M16	10.0	33	8.0	3.5	68.0	142.0	250	32.0	22030.0056
M20	12.0	43	10.0	4.5	84.0	166.0	250	67.0	22030.0060
M24	15.0	48	12.0	5.5	127.0	237.0	250	106.0	22030.0064
<b>stainless steel, standard spring load</b>									
M 3	1.5	8	1.5	0.4	3.0	4.5	250	0.2	22030.0203
M 4	2.5	12	2.0	0.8	8.5	14.0	250	0.6	22030.0204
M 5	3.0	14	2.5	0.9	8.0	14.0	250	1.2	22030.0205
M 6	3.5	15	3.0	1.0	11.0	18.0	250	1.7	22030.0206
M 8	4.5	18	4.0	1.5	18.0	31.0	250	4.0	22030.0208
M10	6.0	23	5.0	2.0	24.0	45.0	250	8.0	22030.0210
M12	8.0	26	6.0	2.5	26.0	49.0	250	12.0	22030.0212
M16	10.0	33	8.0	3.5	41.0	86.0	250	32.0	22030.0216
M20	12.0	43	10.0	4.5	56.0	111.0	250	67.0	22030.0220
M24	15.0	48	12.0	5.5	81.0	151.0	250	106.0	22030.0224
<b>stainless steel, heavy spring load</b>									
M 3	1.5	8	1.5	0.4	5.0	9.0	250	0.3	22030.0243
M 4	2.5	12	2.0	0.8	12.0	18.0	250	0.6	22030.0244
M 5	3.0	14	2.5	0.9	15.0	22.0	250	1.2	22030.0245
M 6	3.5	15	3.0	1.0	19.0	28.0	250	1.8	22030.0246
M 8	4.5	18	4.0	1.5	36.0	62.0	250	4.0	22030.0248
M10	6.0	23	5.0	2.0	57.0	104.0	250	8.2	22030.0250
M12	8.0	26	6.0	2.5	61.0	110.0	250	13.0	22030.0252
M16	10.0	33	8.0	3.5	68.0	142.0	250	32.0	22030.0256
M20	12.0	43	10.0	4.5	84.0	166.0	250	67.0	22030.0260
M24	15.0	48	12.0	5.5	127.0	237.0	250	106.0	22030.0264

<sup>1)</sup> statistical average value

### Application example

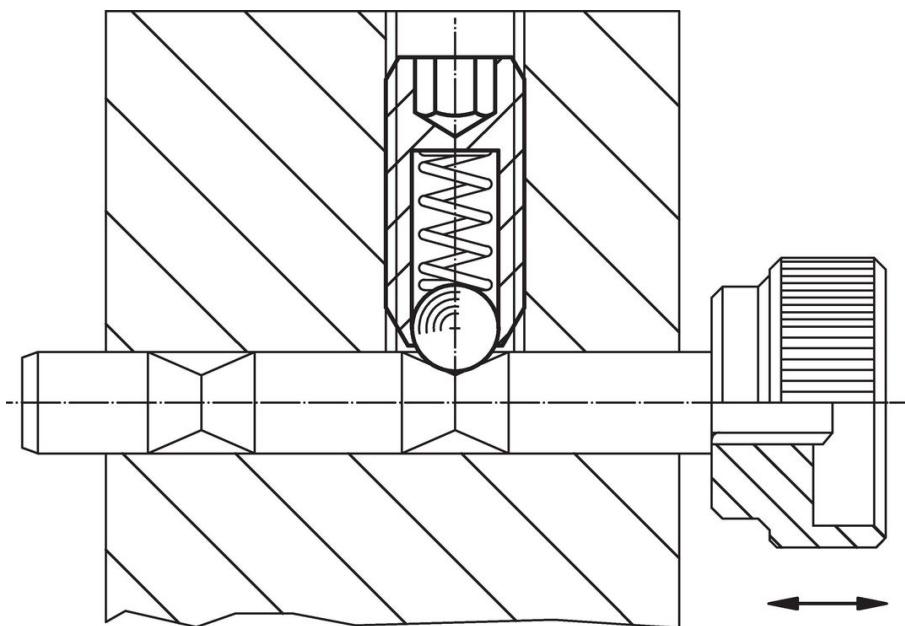

### Compliance

For detailed compliance information please select the desired article number.