

Clamping Bars • length 100  
EH 1585.

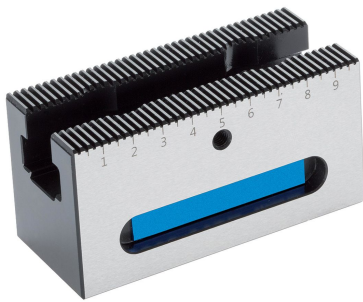

Product Description

Material

- Tool steel, hardened

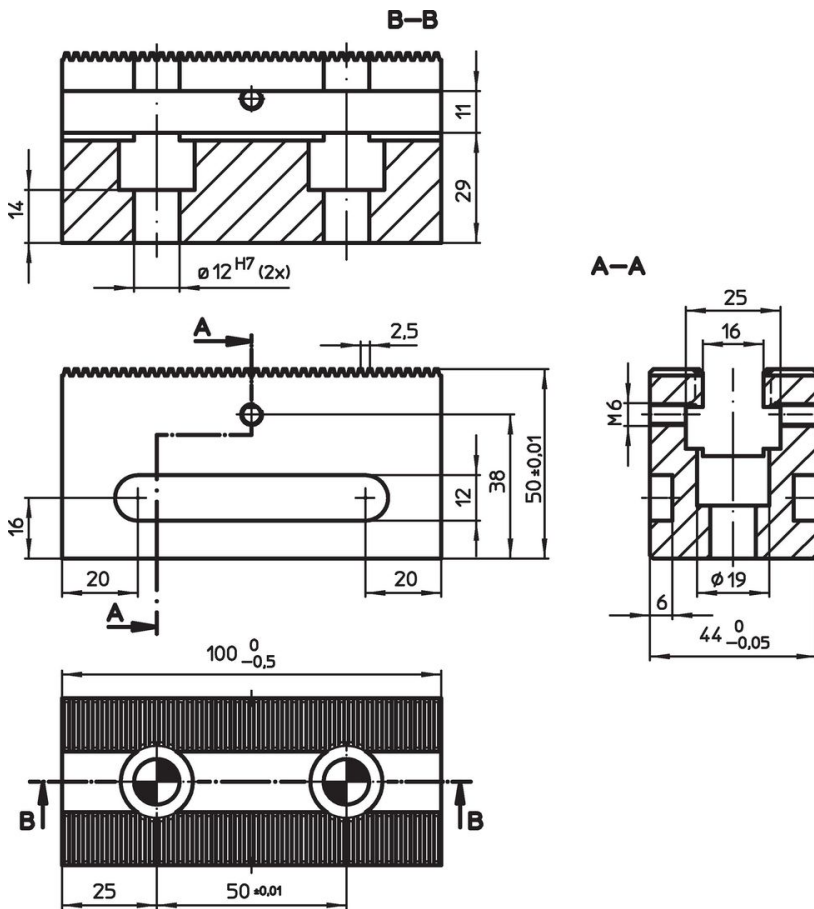

Drawing



Order information

 [g]	Art. No.
1168	1585.100

Accessories

	Number locating screws M12 x 45	 [g]	Art. No.
<b>fixing screws for clamping bars</b>			
	2	106	<a href="#">1585.101</a>

Compliance

For detailed compliance information please select the desired article number.