

Spring Plungers • with pin and slot - INCH

EH 2B020.



Product Description

To be used for positioning, indexing, locking, latching as well as for other similar pressure applications.

Spring plungers can be used for locating or for applying pressure, as a detent or for ejection.

Material

Pin

- Free cutting steel, hardened, blackened
- Stainless Steel 1.4305 (ASTM-A-582), nitrided

Body

- Free cutting steel, blackened
- Stainless steel 1.4305 (ASTM-A-582)

Spring

- Stainless steel

Characteristic

Standard spring load: no marking

Heavy spring load: marked with two lines

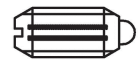
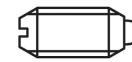

Standard spring load

Heavy spring load

More information

Notes

Customized design on request.

Spring plungers are specially tested for spring range and forces.

- This product is manufactured in INCH dimensions.

References

A conversion table can be found in the technical data following these product information pages.

Thread lock: polyamide spot coating (for details please refer to the technical appendix).

Further products

- Spring Plungers, with pin and slot

Drawing

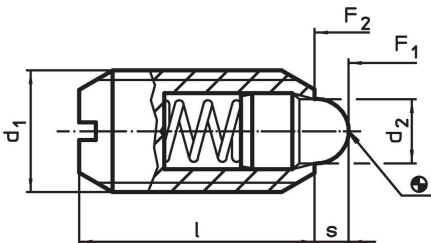

Order information

d ₁	Dimensions		Thread	d ₂	l	Stroke s	Spring load ¹⁾		Temperature		oz	Art. No.
	[in]						F ₁	F ₂	min.	max.		
free cutting steel, standard spring load, Without thread lock												
#6-32		0.138	2A-UNC	0.046	3/8	0.063	0.5	1.5	-22	482	0.013	2B020.0033
#8-32		0.164	2A-UNC	0.070	7/16	0.052	0.8	1.5	-22	482	0.023	2B020.0036
#8-36		0.164	2A-UNF	0.070	7/16	0.052	0.8	1.5	-22	482	0.024	2B020.0038
#10-32		0.190	2A-UNF	0.093	15/32	0.065	1.0	2.5	-22	482	0.036	2B020.0040
1/4-20	1/4	0.250	2A-UNC	0.119	17/32	0.078	1.1	3.5	-22	482	0.062	2B020.0042
5/16-18	5/16	0.313	2A-UNC	0.135	37/64	0.084	1.0	4.0	-22	482	0.123	2B020.0046
3/8-16	3/8	0.375	2A-UNC	0.186	5/8	0.110	1.5	4.5	-22	482	0.187	2B020.0048
1/2-13	1/2	0.500	2A-UNC	0.248	3/4	0.151	1.8	5.5	-22	482	0.377	2B020.0050
5/8-11	5/8	0.625	2A-UNC	0.310	1 1/16	0.215	2.0	8.5	-22	482	0.885	2B020.0052

¹⁾ statistical average value

d ₁		Dimensions				Stroke s	Spring load ¹⁾		min. max.		oz	Art. No.
		Thread	d ₂	l	[in]		F ₁ ~	F ₂ ~	[°F]			
[in]					[in]	[lb]						
free cutting steel, standard spring load, With thread lock												
#6-32		0.138	2A-UNC	0.046	3/8	0.063	0.5	1.5	-22	194	0.013	2B020.0233
#8-32		0.164	2A-UNC	0.070	7/16	0.052	0.8	1.5	-22	194	0.023	2B020.0236
#8-36		0.164	2A-UNF	0.070	7/16	0.052	0.8	1.5	-22	194	0.032	2B020.0238
#10-32		0.190	2A-UNF	0.093	15/32	0.065	1.0	2.5	-22	194	0.042	2B020.0240
1/4-20	1/4	0.250	2A-UNC	0.119	17/32	0.078	1.1	3.5	-22	194	0.064	2B020.0242
5/16-18	5/16	0.313	2A-UNC	0.135	37/64	0.084	1.0	4.0	-22	194	0.115	2B020.0246
3/8-16	3/8	0.375	2A-UNC	0.186	5/8	0.110	1.5	4.5	-22	194	0.190	2B020.0248
1/2-13	1/2	0.500	2A-UNC	0.248	3/4	0.151	1.8	5.5	-22	194	0.377	2B020.0250
5/8-11	5/8	0.625	2A-UNC	0.310	1 1/16	0.215	2.0	8.5	-22	194	0.885	2B020.0252
free cutting steel, heavy spring load, Without thread lock												
#6-32		0.138	2A-UNC	0.046	3/8	0.063	0.5	2.5	-22	482	0.022	2B020.0063
#8-32		0.164	2A-UNC	0.070	7/16	0.052	1.8	4.6	-22	482	0.023	2B020.0066
#8-36		0.164	2A-UNF	0.070	7/16	0.052	1.8	4.6	-22	482	0.032	2B020.0068
#10-32		0.190	2A-UNF	0.093	15/32	0.065	2.6	6.3	-22	482	0.042	2B020.0070
1/4-20	1/4	0.250	2A-UNC	0.119	17/32	0.078	3.0	9.7	-22	482	0.065	2B020.0072
5/16-18	5/16	0.313	2A-UNC	0.135	37/64	0.084	3.8	13.0	-22	482	0.116	2B020.0076
3/8-16	3/8	0.375	2A-UNC	0.186	5/8	0.110	4.5	16.0	-22	482	0.190	2B020.0078
1/2-13	1/2	0.500	2A-UNC	0.248	3/4	0.151	5.0	22.4	-22	482	0.384	2B020.0080
5/8-11	5/8	0.625	2A-UNC	0.310	1 1/16	0.215	7.0	43.5	-22	482	0.907	2B020.0082
free cutting steel, heavy spring load, With thread lock												
#6-32		0.138	2A-UNC	0.046	3/8	0.063	0.5	2.5	-22	194	0.021	2B020.0263
#8-32		0.164	2A-UNC	0.070	7/16	0.052	1.8	4.6	-22	194	0.023	2B020.0266
#8-36		0.164	2A-UNF	0.070	7/16	0.052	1.8	4.6	-22	194	0.032	2B020.0268
#10-32		0.190	2A-UNF	0.093	15/32	0.065	2.6	6.3	-22	194	0.042	2B020.0270
1/4-20	1/4	0.250	2A-UNC	0.119	17/32	0.078	3.0	9.7	-22	194	0.074	2B020.0272
5/16-18	5/16	0.313	2A-UNC	0.135	37/64	0.084	3.8	13.0	-22	194	0.123	2B020.0276
3/8-16	3/8	0.375	2A-UNC	0.186	5/8	0.110	4.5	16.0	-22	194	0.190	2B020.0278
1/2-13	1/2	0.500	2A-UNC	0.248	3/4	0.151	5.0	22.4	-22	194	0.388	2B020.0280
5/8-11	5/8	0.625	2A-UNC	0.310	1 1/16	0.215	7.0	43.5	-22	194	0.907	2B020.0282
stainless steel, standard spring load, Without thread lock												
#6-32		0.138	2A-UNC	0.046	3/8	0.063	0.5	1.5	-22	482	0.013	2B020.0133
#8-32		0.164	2A-UNC	0.070	7/16	0.052	0.8	1.5	-22	482	0.023	2B020.0136
#8-36		0.164	2A-UNF	0.070	7/16	0.052	0.8	1.5	-22	482	0.024	2B020.0138
#10-32		0.190	2A-UNF	0.093	15/32	0.065	1.0	2.5	-22	482	0.042	2B020.0140
1/4-20	1/4	0.250	2A-UNC	0.119	17/32	0.078	1.1	3.5	-22	482	0.074	2B020.0142
5/16-18	5/16	0.313	2A-UNC	0.135	37/64	0.084	1.0	4.0	-22	482	0.123	2B020.0146
3/8-16	3/8	0.375	2A-UNC	0.186	5/8	0.110	1.5	4.5	-22	482	0.180	2B020.0148
1/2-13	1/2	0.500	2A-UNC	0.248	3/4	0.151	1.8	5.5	-22	482	0.388	2B020.0150
5/8-11	5/8	0.625	2A-UNC	0.310	1 1/16	0.215	2.0	8.5	-22	482	0.892	2B020.0152
stainless steel, standard spring load, With thread lock												
#6-32		0.138	2A-UNC	0.046	3/8	0.063	0.5	1.5	-22	194	0.013	2B020.0333
#8-32		0.164	2A-UNC	0.070	7/16	0.052	0.8	1.5	-22	194	0.023	2B020.0336
#8-36		0.164	2A-UNF	0.070	7/16	0.052	0.8	1.5	-22	194	0.024	2B020.0338
#10-32		0.190	2A-UNF	0.093	15/32	0.065	1.0	2.5	-22	194	0.035	2B020.0340
1/4-20	1/4	0.250	2A-UNC	0.119	17/32	0.078	1.1	3.5	-22	194	0.074	2B020.0342
5/16-18	5/16	0.313	2A-UNC	0.135	37/64	0.084	1.0	4.0	-22	194	0.115	2B020.0346
3/8-16	3/8	0.375	2A-UNC	0.186	5/8	0.110	1.5	4.5	-22	194	0.190	2B020.0348
1/2-13	1/2	0.500	2A-UNC	0.248	3/4	0.151	1.8	5.5	-22	194	0.377	2B020.0350
5/8-11	5/8	0.625	2A-UNC	0.310	1 1/16	0.215	2.0	8.5	-22	194	0.892	2B020.0352
stainless steel, heavy spring load, Without thread lock												
#6-32		0.138	2A-UNC	0.046	3/8	0.063	0.5	2.5	-22	482	0.014	2B020.0163
#8-32		0.164	2A-UNC	0.070	7/16	0.052	1.8	4.6	-22	482	0.032	2B020.0166
#8-36		0.164	2A-UNF	0.070	7/16	0.052	1.8	4.6	-22	482	0.025	2B020.0168
#10-32		0.190	2A-UNF	0.093	15/32	0.065	2.6	6.3	-22	482	0.036	2B020.0170
1/4-20	1/4	0.250	2A-UNC	0.119	17/32	0.078	3.0	9.7	-22	482	0.071	2B020.0172

¹⁾ statistical average value

	Dimensions					Stroke s [in]	Spring load ¹⁾		min. max.		oz]	Art. No.
	d ₁	Thread	d ₂	l [in]	F ₁ ~ [lb]		F ₂ ~ [lb]	min. [°F]	max. [°F]			
	[in]		[in]									
5/16-18	5/16	2A-UNC	0.135	37/64	0.084	3.8	13.0	-22	482	0.123	2B020.0176	
3/8-16	3/8	2A-UNC	0.186	5/8	0.110	4.5	16.0	-22	482	0.183	2B020.0178	
1/2-13	1/2	2A-UNC	0.248	3/4	0.151	5.0	22.4	-22	482	0.399	2B020.0180	
5/8-11	5/8	2A-UNC	0.310	1 1/16	0.215	7.0	43.5	-22	482	0.914	2B020.0182	
stainless steel, heavy spring load, With thread lock												
#6-32		2A-UNC	0.046	3/8	0.063	0.5	2.5	-22	194	0.017	2B020.0363	
#8-32		2A-UNC	0.070	7/16	0.052	1.8	4.6	-22	194	0.032	2B020.0366	
#8-36		2A-UNF	0.070	7/16	0.052	1.8	4.6	-22	194	0.025	2B020.0368	
#10-32		2A-UNF	0.093	15/32	0.065	2.6	6.3	-22	194	0.042	2B020.0370	
1/4-20	1/4	2A-UNC	0.119	17/32	0.078	3.0	9.7	-22	194	0.074	2B020.0372	
5/16-18	5/16	2A-UNC	0.135	37/64	0.084	3.8	13.0	-22	194	0.123	2B020.0376	
3/8-16	3/8	2A-UNC	0.186	5/8	0.110	4.5	16.0	-22	194	0.185	2B020.0378	
1/2-13	1/2	2A-UNC	0.248	3/4	0.151	5.0	22.4	-22	194	0.399	2B020.0380	
5/8-11	5/8	2A-UNC	0.310	1 1/16	0.215	7.0	43.5	-22	194	0.910	2B020.0382	

¹⁾ statistical average value

Application example

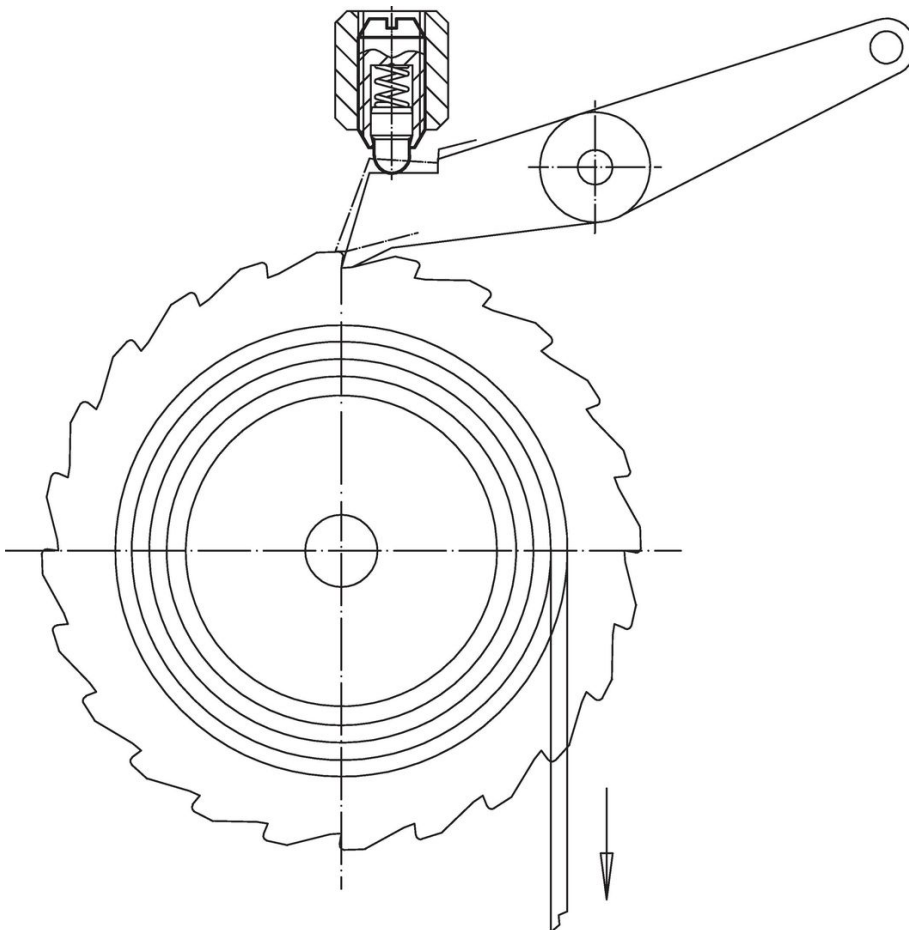

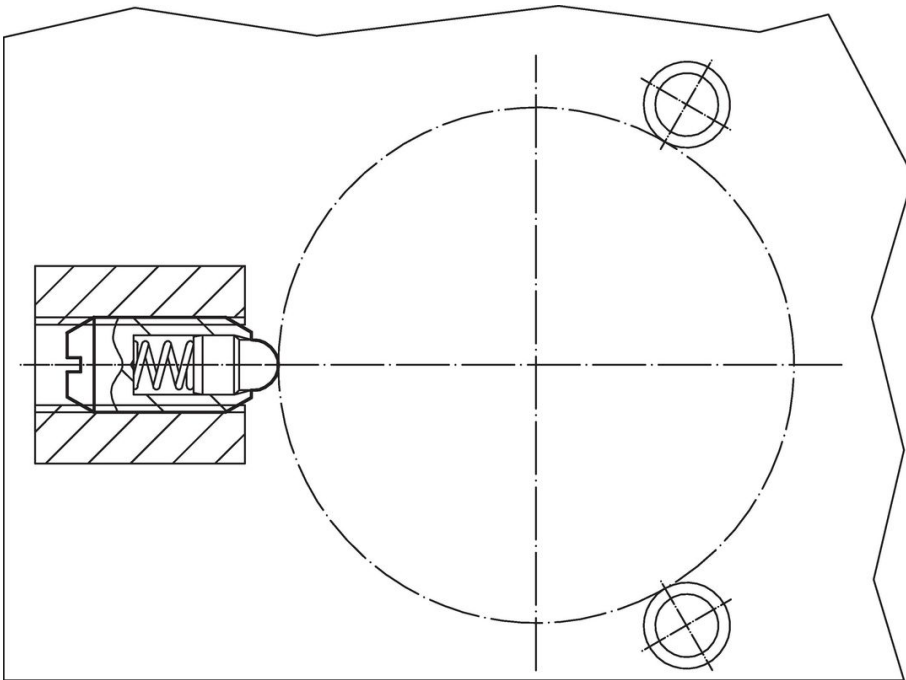

Compliance

For detailed compliance information please select the desired article number.