

Down-Hold Clamps · without clamping lever

EH 23210.

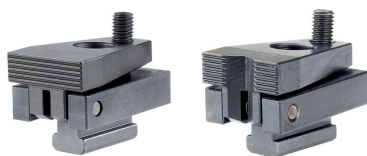

Product Description

By tightening the ball-ended thrust screw the workpiece is simultaneously pressed towards the stops and fixture plate. The favourable leverage enables high horizontal clamping forces. When using T-Nuts EH 23010. / EH 23020. (DIN 508) they can also be applied to other slot sizes.

Material

- Steel, case-hardened, blackened, ground

More information

Further products

- Nuts for T-Slots, DIN 508
- Nuts for T-Slots, extended

Drawing

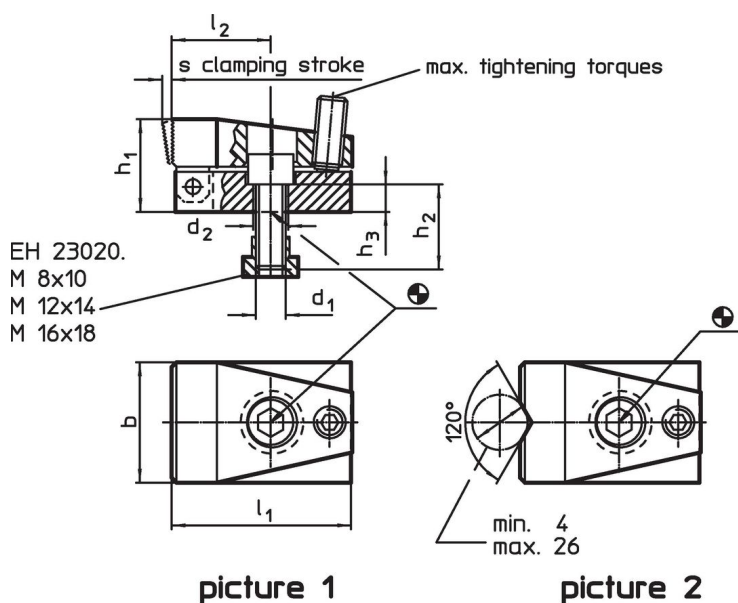

Order information

T-slot size	d ₁	d ₂	b	Dimensions						Clamping force horizontal max. [kN]	Tightening torque max. [Nm]	[g]	Art. No.
				h ₁	h ₂	h ₃	l ₁	l ₂	s				
[mm]				[mm]									
with flat clamping jaw – picture 1													
10	M 8	8.4	32	24	20	8	52	28	3	7.0	3	265	23210.0501
14	M12	12.5	48	37	30	11	72	40	4	15.0	9	838	23210.0521
18	M16	16.5	68	47	35	13	86	41	7	21.5	20	1760	23210.0541
with V-clamping jaw – picture 2													
10	M 8	8.4	32	24	20	8	52	28	3	7.0	3	266	23210.0502
14	M12	12.5	48	37	30	11	72	40	4	15.0	9	829	23210.0522
18	M16	16.5	68	47	35	13	86	41	7	21.5	20	1730	23210.0542

Application example

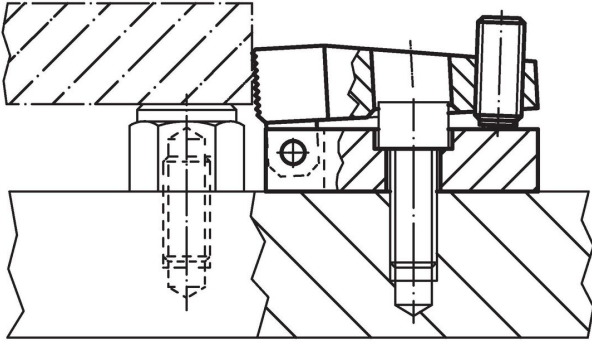

Compliance

RoHS compliant

Contains lead - compliant according to exceptions 6a / 6b / 6c.

Contains SVHC substances >0,1% w/w

Contains lead - SVHC list [REACH] as of 27.06.2024.

Contains Proposition 65 substances



Lead can cause cancer and reproductive harm from exposure
<https://www.P65Warnings.ca.gov/>

Free from Conflict Minerals

This product does not contain any substances designated as "conflict minerals" such as tantalum, tin, gold or tungsten from the Democratic Republic of Congo or adjacent countries.