

Positioning Clamping Pins

EH 23111.



Product Description

The positioning clamping pin allows fast clamping, fastening, adjusting, changing and securing of workpieces, plates, fixture systems etc.

Material

- Heat-treated steel, tempered, blackened
- Stainless steel 1.4542, precipitation-hardened

Operation

By tightening the clamping bolt, the positioning clamping pin is centred and clamped in the locating bushing by means of four balls. The clamping bolt can be operated manually via a removable handle (Art. No. 23111.0900/.0902) or using a hexagon key.

More information

Accessories

Suitable bushings are available.

Further products

- Manual Handles, for positioning clamping pins
- Bushings, for positioning clamping pins
- Locating Bushings, for positioning clamping pins, for press fit
- Locating Bushings, for positioning clamping pins, for screw fit

Drawing

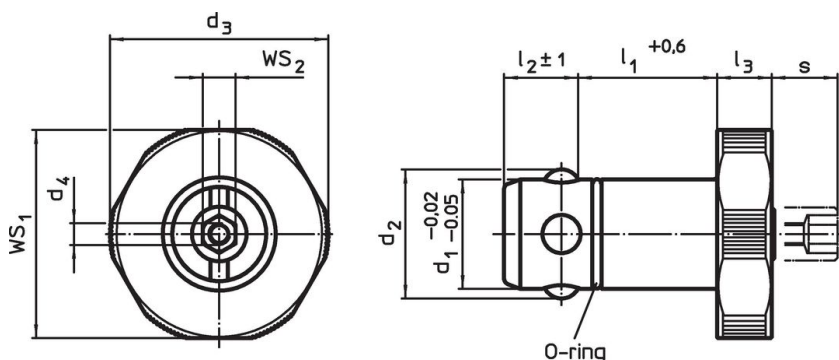

Order information

d_1	l_1	d_2	Dimensions		l_2	l_3	s	For base plates	WS_1	WS_2	Holding force		Art. No.
-0.02 -0.05	+0.6		d_3	d_4	± 1		max.	± 0.05	[mm]	[mm]	[kN]	[g]	
[mm]													
Heat-treated steel													
16	25	18.7	32	M4	13.6	10	9	20	30	6	5	116	23111.0016
16	30	18.7	32	M4	13.6	10	9	25	30	6	5	125	23111.0018
20	25	23.6	40	M4	13.6	10	9	20	38	6	6	178	23111.0020
20	30	23.6	40	M4	13.6	10	9	25	38	6	6	191	23111.0022
25	25	29.0	45	M4	18.6	10	9	20	43	10	8	270	23111.0025
25	30	29.0	45	M4	18.6	10	9	25	43	10	8	287	23111.0027
30	25	34.6	55	M4	18.6	10	9	20	53	10	10	390	23111.0030
30	30	34.6	55	M4	18.6	10	9	25	53	10	10	416	23111.0032
Stainless steel													
16	25	18.7	32	M4	13.6	10	9	20	30	6	5	116	23111.0116
16	30	18.7	32	M4	13.6	10	9	25	30	6	5	125	23111.0118
20	25	23.6	40	M4	13.6	10	9	20	38	6	6	178	23111.0120
20	30	23.6	40	M4	13.6	10	9	25	38	6	6	191	23111.0122

d ₁ -0.02 -0.05	l ₁ +0.6	d ₂	Dimensions					For base plates ±0.05	WS ₁	WS ₂	Holding force		Art. No.
			d ₃	d ₄	l ₂ ±1	l ₃	s max.						
[mm]													[g]
25	25	29.0	45	M4	18.6	10	9	20	43	10	8	270	23111.0125
25	30	29.0	45	M4	18.6	10	9	25	43	10	8	287	23111.0127
30	25	34.6	55	M4	18.6	10	9	20	53	10	10	390	23111.0130
30	30	34.6	55	M4	18.6	10	9	25	53	10	10	416	23111.0132

Application example

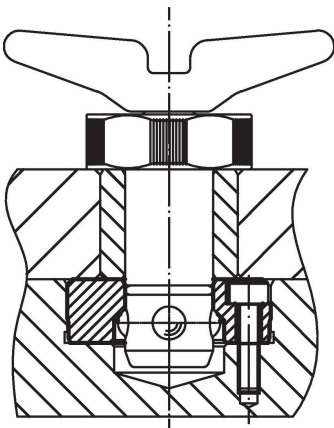
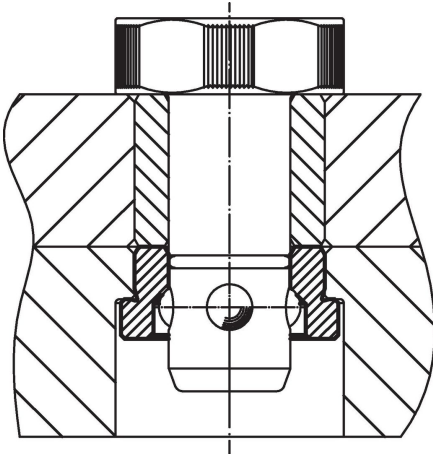
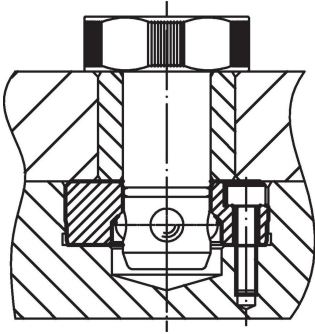

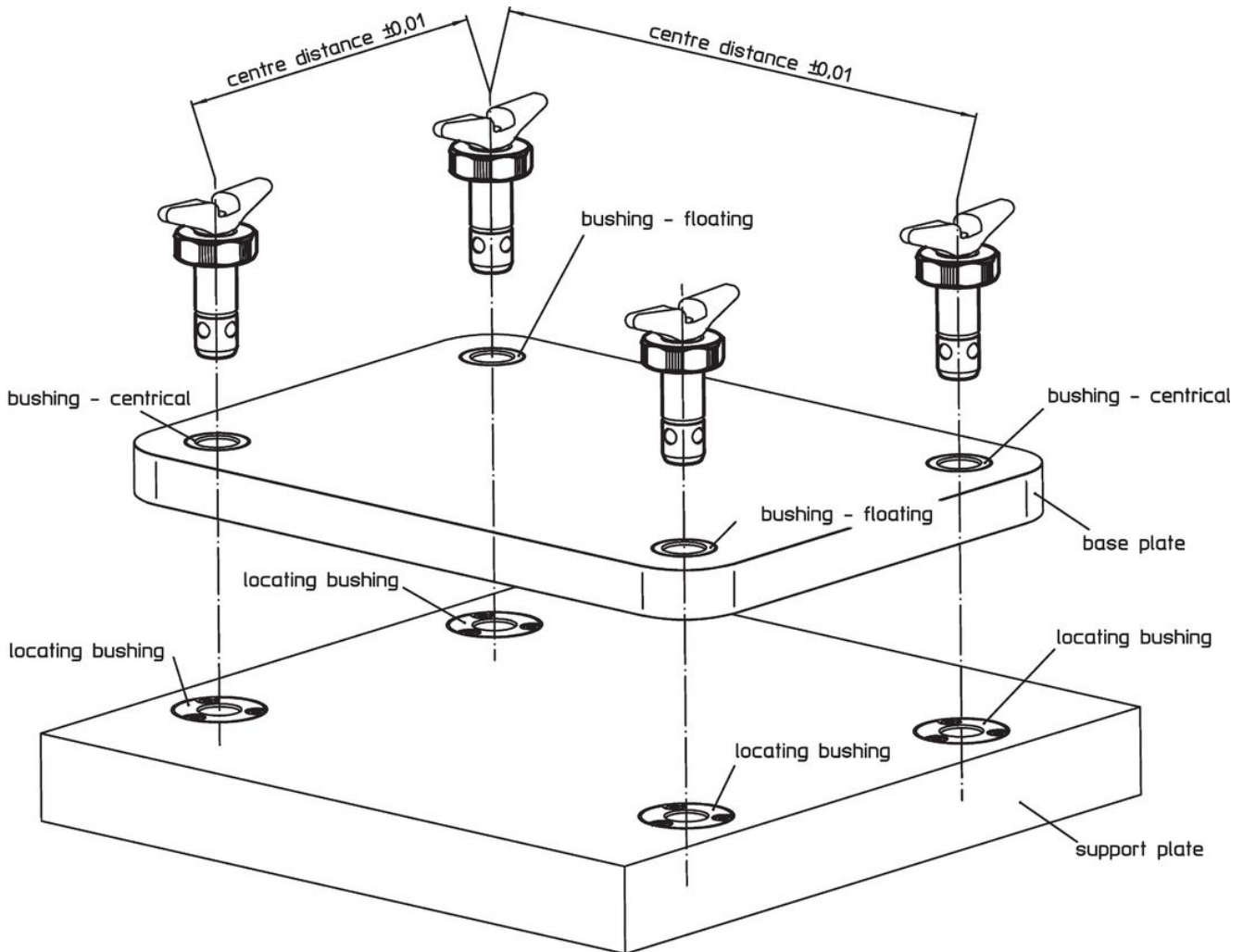

Compliance

For detailed compliance information please select the desired article number.