

Collar Nuts with Conical Seat

EH 23080.



Product Description

With this combination of fixture nut and conical seat, non-parallel clamping surfaces can be compensated.

The fixture nut with conical seat is a fixed unit consisting of fixture nut and conical seat with the following advantages / characteristics:

- Functionally reliable
- Captive
- Fast and efficient mounting
- Simplified storage
- Swivel range max. 3°

Material

Conical seat

- Heat-treated steel, tempered, blackened

Nut

- Heat-treated steel, tempered, blackened

More information

References

For torques and strengths please refer to appendix - Technical Data -

Drawing

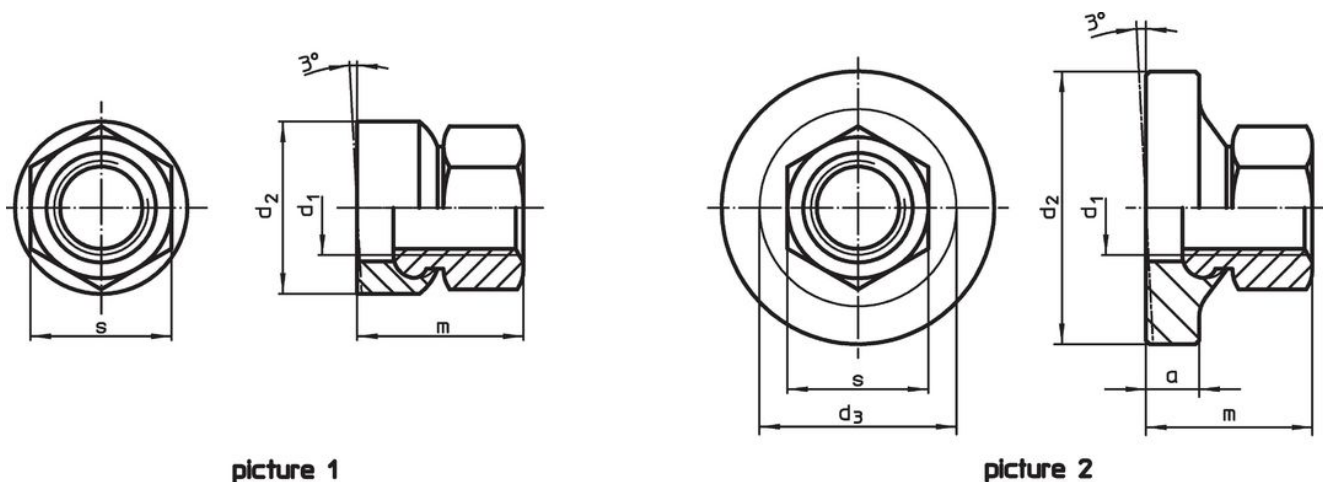

picture 1

picture 2

Order information

d ₁	a	Dimensions			m	s	[g]	Art. No.
		d ₂	d ₃	[mm]				
with small bearing surface – picture 1								
M 8	–	17	–	14.0	13	13	23080.0508	
M10	–	21	–	17.5	16	24	23080.0510	
M12	–	24	–	21.5	18	37	23080.0512	
M16	–	30	–	28.0	24	73	23080.0516	
M20	–	36	–	35.0	30	141	23080.0520	
M24	–	44	–	42.5	36	259	23080.0524	
M30	–	55	–	56.0	46	544	23080.0530	
with large bearing surface – picture 2								
M 8	4.0	24	17.8	14.0	13	20	23080.0608	
M10	5.5	30	21.2	17.5	16	39	23080.0610	
M12	7.0	36	25.2	21.5	18	68	23080.0612	
M16	8.0	44	30.9	28.0	24	124	23080.0616	
M20	9.5	50	39.9	35.0	30	213	23080.0620	
M24	11.0	60	49.6	42.5	36	378	23080.0624	
M30	14.0	68	61.3	56.0	46	691	23080.0630	

Application example



Compliance

For detailed compliance information please select the desired article number.