

Rod Ends • DIN 12240-4, with female thread EH 22982.



Product Description

Rod ends are suitable for universal use in applications subject to dynamic loads. As well as use in corrosion-risk areas, the design in stainless steel can also be used under higher dynamic loads. Rod ends are used for bearings where movements between shaft and housing are necessary, and where the movements are not in a straight line.

Rod ends are ready-to-install elements manufactured to DIN ISO 12240-4 (dimension series K). The PTFE fabric inserted into the bearing shell means that the rod ends are maintenance-free. **Please take note of the technical information which follows these product pages.**

Material

Body

- Free cutting steel, turned, zinc-plated
- Stainless steel 1.4057, forged, polished

Joint ball

- Roller bearing steel, hardened, ground, polished
- Stainless steel 1.4034, hardened, ground, polished

Bearing

- PTFE fabric



Bearing shell

- Free cutting steel, zinc-plated by galvanization
- Stainless steel 1.4571

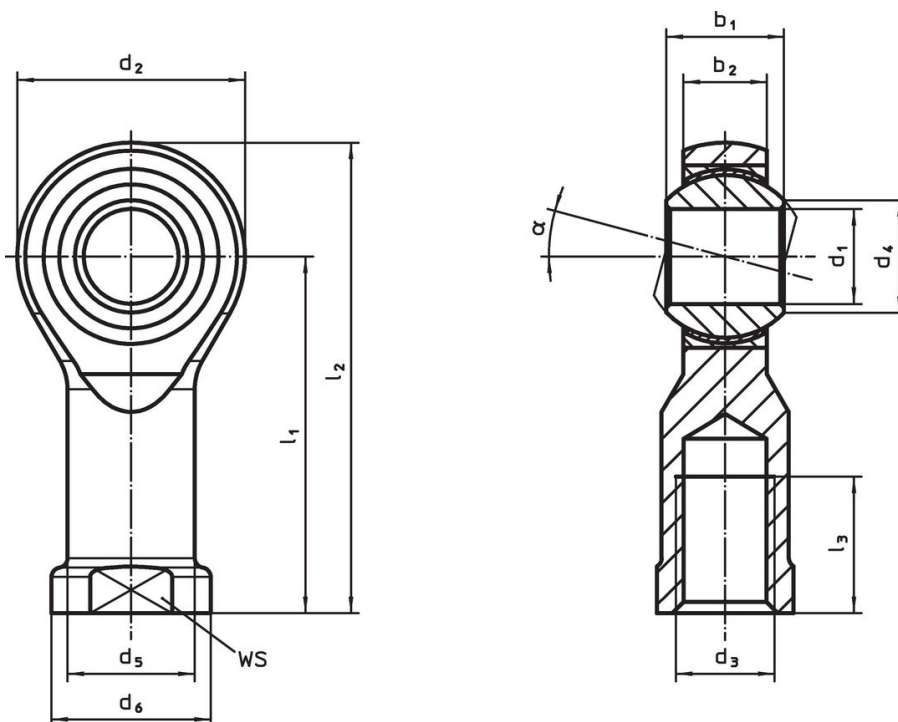
Drawing



Order information

Dimensions											α	WS [mm]	Dynamic carrying figure C [kN]	Static carrying figure C ₀ [kN]	 min. max.		 [g]	Art. No.
d ₁	l ₁	b ₁	b ₂	d ₂	d ₃	d ₄	d ₅	d ₆	l ₂	l ₃					[mm]			
right hand thread, Free cutting steel																		
5	27	8	6.00	18	M 5	7.7	9.0	11	36	10	13°	9	7.5	8.0	-50	150	18	22982.0202
6	30	9	6.75	20	M 6	8.9	10.0	13	40	12	13°	11	9.3	8.9	-50	150	26	22982.0204
8	36	12	9.00	24	M 8	10.4	12.5	16	48	16	14°	13	16.7	14.1	-50	150	47	22982.0206
10	43	14	10.50	28	M10	12.9	15.0	19	57	20	13°	17	23.4	19.3	-50	150	76	22982.0208
12	50	16	12.00	32	M12	15.4	17.5	22	66	22	13°	19	32.0	23.5	-50	150	113	22982.0210
14	57	19	13.50	36	M14	16.8	20.0	25	75	25	16°	22	42.0	21.0	-50	150	165	22982.0212
16	64	21	15.00	42	M16	19.3	22.0	27	85	28	15°	22	52.5	32.0	-50	150	235	22982.0214
18	71	23	16.50	46	M18 x 1,5	21.8	25.0	31	94	32	15°	27	64.0	38.5	-50	150	317	22982.0216
20	77	25	18.00	50	M20 x 1,5	24.3	27.5	34	102	33	14°	32	78.0	44.0	-50	150	413	22982.0218
22	84	28	20.00	54	M22 x 1,5	25.8	30.0	37	111	37	15°	32	97.0	53.0	-50	150	528	22982.0220
25	94	31	22.00	60	M24 x 2	29.6	33.5	42	124	42	15°	36	122.0	62.0	-50	150	725	22982.0222
right hand thread, Stainless steel																		
5	27	8	6.00	18	M 5	7.7	9.0	11	36	10	13°	9	7.5	11.8	-50	150	18	22982.0402
6	30	9	6.75	20	M 6	8.9	10.0	13	40	12	13°	11	9.3	13.1	-50	150	26	22982.0404
8	36	12	9.00	24	M 8	10.4	12.5	16	48	16	14°	13	16.7	20.7	-50	150	47	22982.0406
10	43	14	10.50	28	M10	12.9	15.0	19	57	20	13°	17	23.4	28.3	-50	150	76	22982.0408
12	50	16	12.00	32	M12	15.4	17.5	22	66	22	13°	19	32.0	34.5	-50	150	113	22982.0410
14	57	19	13.50	36	M14	16.8	20.0	25	75	25	16°	22	42.0	39.5	-50	150	165	22982.0412
16	64	21	15.00	42	M16	19.3	22.0	27	85	28	15°	22	52.5	60.5	-50	150	235	22982.0414
18	71	23	16.50	46	M18 x 1,5	21.8	25.0	31	94	32	15°	27	64.0	73.0	-50	150	317	22982.0416
20	77	25	18.00	50	M20 x 1,5	24.3	27.5	34	102	33	14°	32	78.0	83.0	-50	150	413	22982.0418
22	84	28	20.00	54	M22 x 1,5	25.8	30.0	37	111	37	15°	32	97.0	100.0	-50	150	528	22982.0420
25	94	31	22.00	60	M24 x 2	29.6	33.5	42	124	42	15°	36	122.0	118.0	-50	150	725	22982.0422
left hand thread, Free cutting steel																		
5	27	8	6.00	18	M 5	7.7	9.0	11	36	10	13°	9	7.5	8.0	-50	150	19	22982.0224
6	30	9	6.75	20	M 6	8.9	10.0	13	40	12	13°	11	9.3	8.9	-50	150	26	22982.0226
8	36	12	9.00	24	M 8	10.4	12.5	16	48	16	14°	13	16.7	14.1	-50	150	47	22982.0228
10	43	14	10.50	28	M10	12.9	15.0	19	57	20	13°	17	23.4	19.3	-50	150	76	22982.0230
12	50	16	12.00	32	M12	15.4	17.5	22	66	22	13°	19	32.0	23.5	-50	150	113	22982.0232
14	57	19	13.50	36	M14	16.8	20.0	25	75	25	16°	22	42.0	21.0	-50	150	164	22982.0234
16	64	21	15.00	42	M16	19.3	22.0	27	85	28	15°	22	52.5	32.0	-50	150	235	22982.0236
18	71	23	16.50	46	M18 x 1,5	21.8	25.0	31	94	32	15°	27	64.0	38.5	-50	150	318	22982.0238
20	77	25	18.00	50	M20 x 1,5	24.3	27.5	34	102	33	14°	32	78.0	44.0	-50	150	416	22982.0240
22	84	28	20.00	54	M22 x 1,5	25.8	30.0	37	111	37	15°	32	97.0	53.0	-50	150	526	22982.0242
25	94	31	22.00	60	M24 x 2	29.6	33.5	42	124	42	15°	36	122.0	62.0	-50	150	716	22982.0244
left hand thread, Stainless steel																		
5	27	8	6.00	18	M 5	7.7	9.0	11	36	10	13°	9	7.5	11.8	-50	150	19	22982.0424
6	30	9	6.75	20	M 6	8.9	10.0	13	40	12	13°	11	9.3	13.1	-50	150	26	22982.0426
8	36	12	9.00	24	M 8	10.4	12.5	16	48	16	14°	13	16.7	20.7	-50	150	47	22982.0428
10	43	14	10.50	28	M10	12.9	15.0	19	57	20	13°	17	23.4	28.3	-50	150	76	22982.0430
12	50	16	12.00	32	M12	15.4	17.5	22	66	22	13°	19	32.0	34.5	-50	150	113	22982.0432
14	57	19	13.50	36	M14	16.8	20.0	25	75	25	16°	22	42.0	39.5	-50	150	164	22982.0434
16	64	21	15.00	42	M16	19.3	22.0	27	85	28	15°	22	52.5	60.5	-50	150	235	22982.0436
18	71	23	16.50	46	M18 x 1,5	21.8	25.0	31	94	32	15°	27	64.0	73.0	-50	150	318	22982.0438
20	77	25	18.00	50	M20 x 1,5	24.3	27.5	34	102	33	14°	32	78.0	83.0	-50	150	416	22982.0440
22	84	28	20.00	54	M22 x 1,5	25.8	30.0	37	111	37	15°	32	97.0	100.0	-50	150	526	22982.0442
25	94	31	22.00	60	M24 x 2	29.6	33.5	42	124	42	15°	36	122.0	118.0	-50	150	716	22982.0444

Compliance

For detailed compliance information please select the desired article number.