

Mounting Pads • protected against slipping

EH 22590.



Product Description

Mounting pads can be used as foot or thrust pad. Not parallel bearing surfaces up to 15° degrees can be compensated.
The plastic cover on the mounting pad prevents slipping.

Material

Ball element

- Free cutting steel, induction-hardened, blackened.
- Stainless steel 1.4305

Ball element with bolt

- Heat-treated steel, blackened
- Stainless steel 1.4305

Rubber cap

- Rubber, black

Lock nut

- Steel, blackened, ISO 4032
- Steel, blackened, DIN 934
- Stainless Steel A2, ISO 4032
- Stainless Steel A2, DIN 934

Pad

- Heat-treated steel, tempered, blackened
- Stainless steel 1.4305
- Thermoplastic POM, white

More information

Notes

For the versions $d_1 = M10$ and $M12$ the lock nut conforms to DIN 934.

Drawing

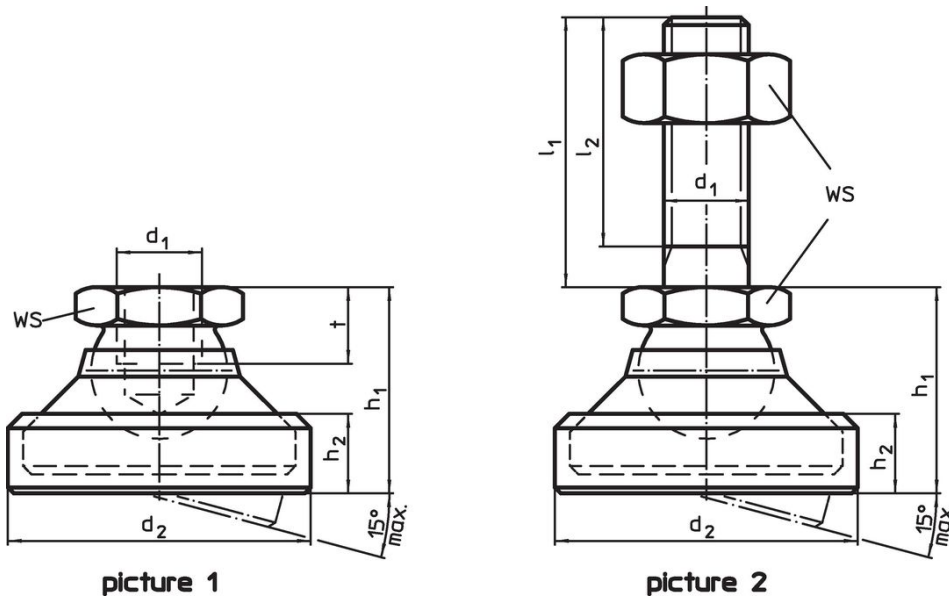

picture 1

picture 2

Order information

d_1	l_1	d_2	Dimensions				WS	Load capacity for static load max.	[g]	Art. No.
			l_2	h_1	h_2	t				
[mm]										
pad and ball element – picture 1, Heat-treated steel										
M 6	–	22.5	–	16.5	6.4	5.0	10	10	19.0	22590.1006
M 8	–	28.0	–	20.6	8.3	7.0	13	18	40.0	22590.1008
M10	–	36.0	–	26.0	11.0	9.0	17	20	80.0	22590.1010

d ₁	l ₁	d ₂	Dimensions				t	WS [mm]	Load capacity for static load max. [kN]	 [g]	Art. No.
			l ₂	h ₁ ~	h ₂	[mm]					
M12	–	45.0	–	30.5	13.2	11.0	19	35	126.0	22590.1012	
M16	–	56.0	–	37.5	15.5	13.5	24	45	241.0	22590.1016	
M20	–	67.0	–	49.5	19.5	17.0	30	55	480.0	22590.1020	
M24	–	69.0	–	55.0	24.0	19.0	36	65	554.0	22590.1024	
pad and ball element – picture 1, Stainless steel											
M 6	–	22.5	–	16.5	6.4	5.0	10	8	17.0	22590.1206	
M 8	–	28.0	–	20.6	8.3	7.0	13	14	36.0	22590.1208	
M10	–	36.0	–	26.0	11.0	9.0	17	16	74.0	22590.1210	
M12	–	45.0	–	30.5	13.2	11.0	19	28	123.0	22590.1212	
M16	–	56.0	–	37.5	15.5	13.5	24	36	241.0	22590.1216	
M20	–	67.0	–	49.5	19.5	17.0	30	44	500.0	22590.1220	
M24	–	69.0	–	55.0	24.0	19.0	36	52	517.0	22590.1224	
pad from thermoplastic, ball element from stainless steel – picture 1, Thermoplastic											
M 6	–	22.5	–	16.5	6.4	5.0	10	4	7.8	22590.1106	
M 8	–	28.0	–	20.6	8.3	7.0	13	7	17.0	22590.1108	
M10	–	36.0	–	26.0	11.0	9.0	17	10	34.0	22590.1110	
M12	–	45.0	–	30.5	13.2	11.0	19	18	57.0	22590.1112	
M16	–	56.0	–	37.5	15.5	13.5	24	20	96.0	22590.1116	
M20	–	67.0	–	49.5	19.5	17.0	30	22	190.0	22590.1120	
M24	–	69.0	–	55.0	24.0	19.0	36	25	240.0	22590.1124	
pad and ball element with bolt from steel – picture 2, Heat-treated steel											
M 6	60	22.5	57.0	16.5	6.4	–	10	10	32.0	22590.1410	
M 8	80	28.0	76.0	20.6	8.3	–	13	18	69.0	22590.1422	
M10	100	36.0	95.5	26.0	11.0	–	17	20	139.0	22590.1438	
M10	150	36.0	145.5	26.0	11.0	–	17	20	165.0	22590.1442	
M12	100	45.0	94.5	30.5	13.2	–	19	35	252.0	22590.1452	
M12	150	45.0	144.5	30.5	13.2	–	19	35	258.0	22590.1456	
M16	100	56.0	94.0	37.5	15.5	–	24	45	440.0	22590.1468	
M16	200	56.0	194.0	37.5	15.5	–	24	45	600.0	22590.1472	
M20	100	67.0	92.5	49.5	19.5	–	30	55	762.0	22590.1482	
M20	200	67.0	192.5	49.5	19.5	–	30	55	1080.0	22590.1488	
M24	100	69.0	91.0	55.0	24.0	–	36	65	1020.0	22590.1495	
M24	200	69.0	191.0	55.0	24.0	–	36	65	1287.0	22590.1498	
pad and ball element with bolt from steel – picture 2, Stainless steel											
M 6	60	22.5	57.0	16.5	6.4	–	10	8	30.0	22590.1610	
M 8	80	28.0	76.0	20.6	8.3	–	13	14	71.0	22590.1622	
M10	100	36.0	95.5	26.0	11.0	–	17	16	150.0	22590.1638	
M10	150	36.0	145.5	26.0	11.0	–	17	16	169.0	22590.1642	
M12	100	45.0	94.5	30.5	13.2	–	19	28	227.0	22590.1652	
M12	150	45.0	144.5	30.5	13.2	–	19	28	258.0	22590.1656	
M16	100	56.0	94.0	37.5	15.5	–	24	36	441.0	22590.1668	
M16	200	56.0	194.0	37.5	15.5	–	24	36	630.0	22590.1672	
M20	100	67.0	92.5	49.5	19.5	–	30	44	762.0	22590.1682	
M20	200	67.0	192.5	49.5	19.5	–	30	44	1065.0	22590.1688	
M24	100	69.0	91.0	55.0	24.0	–	36	52	1000.0	22590.1695	
M24	200	69.0	191.0	55.0	24.0	–	36	52	1287.0	22590.1698	
pad from thermoplastic, ball element with bolt from stainless steel – picture 2, Thermoplastic											
M 6	60	22.5	57.0	16.5	6.4	–	10	4	21.0	22590.1510	
M 8	80	28.0	76.0	20.6	8.3	–	13	7	49.0	22590.1522	
M10	100	36.0	95.5	26.0	11.0	–	17	10	100.0	22590.1538	
M10	150	36.0	145.5	26.0	11.0	–	17	10	124.0	22590.1542	
M12	100	45.0	94.5	30.5	13.2	–	19	18	150.0	22590.1552	
M12	150	45.0	144.5	30.5	13.2	–	19	18	184.0	22590.1556	
M16	100	56.0	94.0	37.5	15.5	–	24	20	285.0	22590.1568	
M16	200	56.0	194.0	37.5	15.5	–	24	20	414.0	22590.1572	
M20	100	67.0	92.5	49.5	19.5	–	30	22	573.0	22590.1582	
M20	200	67.0	192.5	49.5	19.5	–	30	22	704.0	22590.1588	
M24	100	69.0	91.0	55.0	24.0	–	36	25	718.0	22590.1595	
M24	200	69.0	191.0	55.0	24.0	–	36	25	1016.0	22590.1598	

Compliance

RoHS compliant

Compliant according to Directive 2011/65/EU and Directive 2015/863.

Does not contain SVHC substances

No SVHC substances with more than 0.1% w/w contained - SVHC list [REACH] as of 23.01.2024.

Does not contain Proposition 65 substances

No Proposition 65 substances included.

<https://www.P65Warnings.ca.gov/>

Free from Conflict Minerals

This product does not contain any substances designated as "conflict minerals" such as tantalum, tin, gold or tungsten from the Democratic Republic of Congo or adjacent countries.