

Lateral Plungers • with thread, with seal

EH 22150.



Product Description

To be used for positioning and applying pressure, e.g. during painting and sandblasting. Sealed against chips and dirt.

Material

Seal

- CR

Body

- Steel, zinc-plated by galvanization

Spring

- Stainless steel
- Steel, blackened
- Steel, zinc-plated by galvanization

Pin

- Steel, case-hardened, zinc-plated by galvanization
- Thermoplastic POM, white

Assembly

Lateral plungers are installed by screwing in by means of a mounting tool.

Formula for calculating the center distance for the mounting hole:

$$l_0 = z/2 + w + x,$$

l_0 = center distance,

y = workpiece height,

w = workpiece length,

x = coordinate dimension,

s = stroke,

z = stop diameter

Calculation dimension x :

y greater than or equal to $l_2 - d_2/2$,

then $x = d_2/2 - s$

(value x for this case see table)

or

y smaller than $l_2 - d_2/2$,

then $x = d_2/2 - s - [(l_2 - d_2/2 - y) * 0,123]$

Characteristic

Version light spring load = spring from stainless steel

Version standard spring load = spring from steel, blackened

Version heavy spring load = spring from steel, zinc-plated by galvanization

Drawing

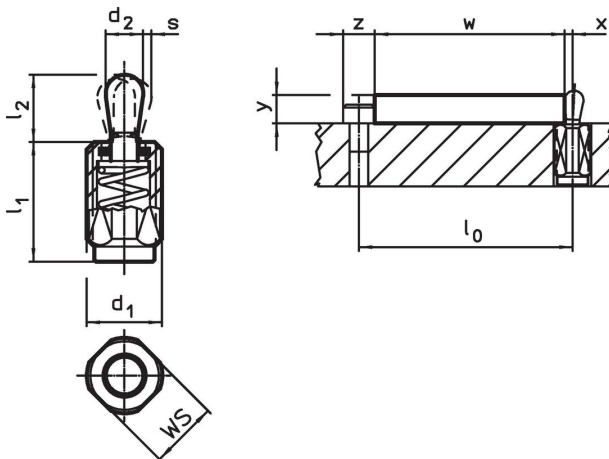



Order information

d ₁ [mm]	Dimensions		d ₂ [mm]	l ₂ [mm]	Stroke s [mm]	WS [mm]	x ¹⁾ [mm]	max. [°C]	 [g]	Art. No.
	l ₁ -2 [mm]	Spring load F max. ²⁾ ~ [N]								
Pin: Steel/Light spring load										
M12	11.5	20	5	6	0.8	10	1.7	110	3.8	22150.0410
M12	19.0	20	5	6	0.8	10	1.7	110	5.6	22150.0414
M12	26.5	20	5	6	0.8	10	1.7	110	7.5	22150.0418
M12	11.5	40	6	10	1.0	10	2.0	110	4.7	22150.0430
M12	19.0	40	6	10	1.0	10	2.0	110	6.5	22150.0434
M12	26.5	40	6	10	1.0	10	2.0	110	8.3	22150.0438
M18 x 1,5	18.0	100	10	16	1.6	16	3.4	110	20.0	22150.0450
M18 x 1,5	31.5	100	10	16	1.6	16	3.4	110	28.0	22150.0454
M18 x 1,5	45.0	100	10	16	1.6	16	3.4	110	36.0	22150.0458
Pin: Steel/Standard spring load										
M12	11.5	50	5	6	0.8	10	1.7	110	4.1	22150.0411
M12	19.0	50	5	6	0.8	10	1.7	110	6.3	22150.0415
M12	26.5	50	5	6	0.8	10	1.7	110	8.1	22150.0419
M12	11.5	75	6	10	1.0	10	2.0	110	4.8	22150.0431
M12	19.0	75	6	10	1.0	10	2.0	110	6.9	22150.0435
M12	26.5	75	6	10	1.0	10	2.0	110	8.9	22150.0439
M18 x 1,5	18.0	150	10	16	1.6	16	3.4	110	20.0	22150.0451
M18 x 1,5	31.5	150	10	16	1.6	16	3.4	110	29.0	22150.0455
M18 x 1,5	45.0	150	10	16	1.6	16	3.4	110	40.0	22150.0459
Pin: Steel/Heavy spring load										
M12	11.5	100	5	6	0.8	10	1.7	110	4.2	22150.0412
M12	19.0	100	5	6	0.8	10	1.7	110	6.6	22150.0416
M12	26.5	100	5	6	0.8	10	1.7	110	8.7	22150.0420
M12	11.5	100	6	10	1.0	10	2.0	110	5.4	22150.0432
M12	19.0	100	6	10	1.0	10	2.0	110	7.6	22150.0436
M12	26.5	100	6	10	1.0	10	2.0	110	10.0	22150.0440
M18 x 1,5	18.0	200	10	16	1.6	16	3.4	110	20.0	22150.0452
M18 x 1,5	31.5	200	10	16	1.6	16	3.4	110	29.0	22150.0456
M18 x 1,5	45.0	200	10	16	1.6	16	3.4	110	38.0	22150.0460
Pin: Thermoplastic/Light spring load										
M12	11.5	20	5	6	0.8	10	1.7	80	2.6	22150.0470
M12	19.0	20	5	6	0.8	10	1.7	80	4.4	22150.0475
M12	26.5	20	5	6	0.8	10	1.7	80	6.1	22150.0483
M12	11.5	40	6	10	1.0	10	2.0	80	2.7	22150.0473
M12	19.0	40	6	10	1.0	10	2.0	80	4.5	22150.0480
M12	26.5	40	6	10	1.0	10	2.0	80	6.2	22150.0485
M18 x 1,5	18.0	100	10	16	1.6	16	3.4	80	12.0	22150.0490
M18 x 1,5	31.5	100	10	16	1.6	16	3.4	80	21.0	22150.0493
M18 x 1,5	45.0	100	10	16	1.6	16	3.4	80	30.0	22150.0495

¹⁾ If the workpiece height (y) is less than l₂-d₂/2, the coordinate dimension (x) must be calculated.

²⁾ statistical average value

Accessories

	Dimensions	 [g]	Art. No.
	d ₁ [mm]		
assembly tool			
	M12	76	22150.0820
	M18 x 1,5	137	22150.0822

Application example

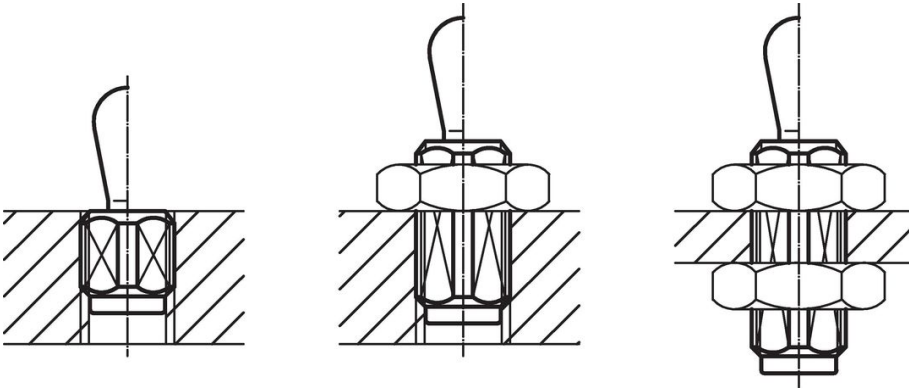

Compliance

For detailed compliance information please select the desired article number.