

Index Plungers • with rapid locking head

EH 22122.



Product Description

Index plungers are used for indexing bores.

Material

Body

- Steel, blackened
- Stainless steel 1.4305

Press button

- Thermoplastic POM, red

Locking pin

- Steel, hardened
- Stainless steel 1.4305, nickel-plated

Knob

- Thermoplastic PA 6, black-grey, matt

Assembly

The screw length can be adapted by distance collars for index plungers (EH 22120.).

Operation

The locking pin is drawn in and locked by pulling the knob. The projecting red press button indicates the locking position (locking pin drawn in). Pushing the red press button causes the locking pin to jump back into the locking position.

More information

Notes

Knob not removable.
Lock nuts have to be purchased separately.

Further products

- Locating Bushings, for index bolts and index plungers
- Distance Collars, for index plungers
- Mounting Blocks, for index bolts and index plungers

Drawing

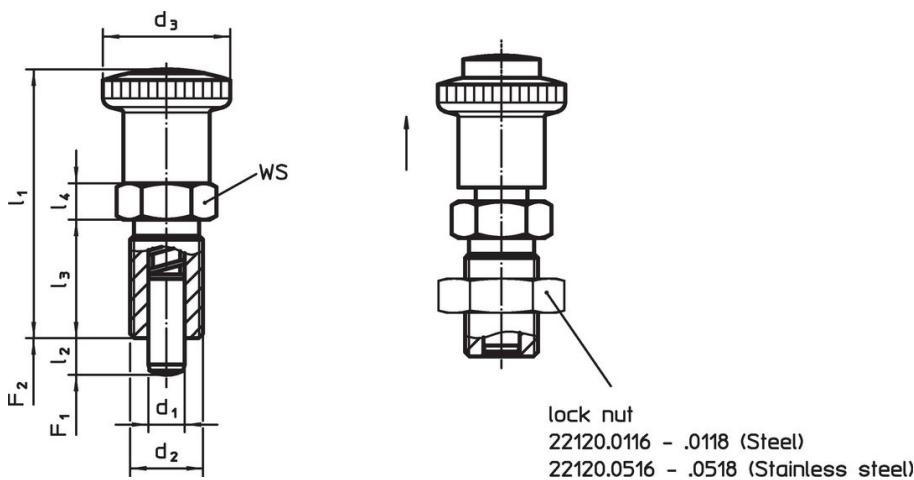

Order information



d ₁	d ₂	Dimensions				WS	Spring load ¹⁾		Temperature		Weight	Art. No.	
		l ₂ min.	d ₃	l ₁ ~	l ₃		l ₄	F ₁ ~	F ₂ ~	min.			max.
		[mm]				[mm]	[N]		[°C]		[g]		
-0.02 -0.04													
Steel													
6	M12 x 1,5	6	30	53.5	22	6	19	6.5	19	-30	80	49	22122.0205
6	M12 x 1,5	9	30	53.5	22	6	19	6.0	25	-30	80	49	22122.0210
8	M16 x 1,5	8	30	59.5	26	8	19	8.5	26	-30	80	75	22122.0215
8	M16 x 1,5	12	30	59.5	26	8	19	8.5	28	-30	80	78	22122.0220
10	M16 x 1,5	12	30	59.5	26	8	19	9.5	38	-30	80	79	22122.0225

¹⁾ statistical average value

d ₁ -0.02 -0.04	d ₂	Dimensions					WS [mm]	Spring load ¹⁾		min. max.		[g]	Art. No.
		l ₂ min.	d ₃ [mm]	l ₁ ~	l ₃	l ₄		F ₁ ~ [N]	F ₂ ~ [N]	[°C]			
Stainless steel													
6	M12 x 1,5	6	30	53.5	22	6	19	6.5	19	-30	80	49	22122.0305
6	M12 x 1,5	9	30	53.5	22	6	19	6.0	25	-30	80	49	22122.0310
8	M16 x 1,5	8	30	59.5	26	8	19	8.5	26	-30	80	75	22122.0315
8	M16 x 1,5	12	30	59.5	26	8	19	8.5	28	-30	80	78	22122.0320
10	M16 x 1,5	12	30	59.5	26	8	19	9.5	38	-30	80	79	22122.0325

¹⁾ statistical average value

Accessories

	Dimensions d ₂ [mm]	Wrench size [mm]	[g]	Art. No.
Steel				
	M12 x 1,5	18	7.5	22120.0116
	M16 x 1,5	24	15.0	22120.0118
Stainless steel				
	M12 x 1,5	18	7.5	22120.0516
	M16 x 1,5	24	15.0	22120.0518

Compliance

For detailed compliance information please select the desired article number.