

Index Plungers · without hexagon collar

EH 22120.



Product Description

Index plungers are used for indexing bores.

Material

Body

- Free cutting steel, blackened
- Stainless steel 1.4305

Locking pin

- Steel, hardened
- Stainless steel 1.4305, nickel-plated

Knob

- Thermoplastic PA 6, black

Assembly

Suitable mounting tools are available.

More information

Notes

Knob not removable.
Lock nuts have to be purchased separately.

Further products

- Mounting Blocks, for index bolts and index plungers, die-cast
- Locating Bushings, for index bolts and index plungers
- Distance Collars, for index plungers

Drawing

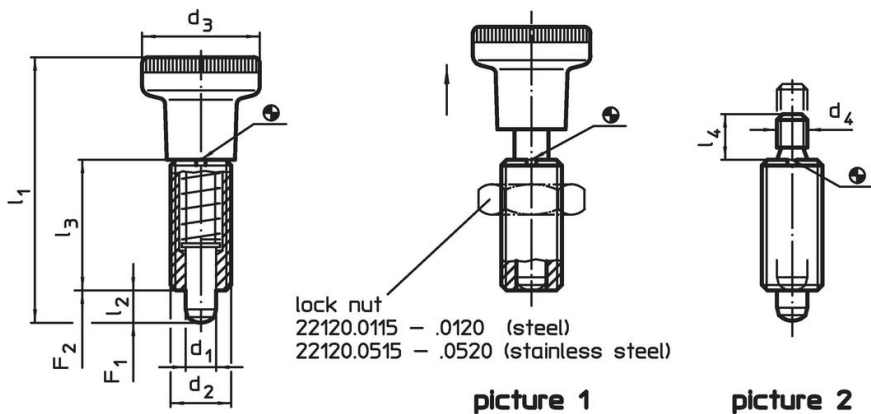

Order information

Dimensions								Spring load ¹⁾		Temperature		Weight [g]	Art. No.
d ₁	d ₂	d ₃	d ₄	l ₁	l ₂ min.	l ₃	l ₄	F ₁	F ₂	min.	max.		
-0.02 -0.05				~				~	~				
[mm]								[N]		[°C]		[g]	
with knob – picture 1, Free cutting steel													
5	M10 x 1	21	–	45.0	5	22	–	6.0	14	-30	80	17	22120.0045
6	M12 x 1,5	25	–	54.5	6	26	–	6.5	19	-30	80	27	22120.0046
8	M16 x 1,5	31	–	69.0	8	34	–	11.5	28	-30	80	63	22120.0048
10	M20 x 1,5	31	–	80.0	10	41	–	23.0	54	-30	80	104	22120.0050
without knob – picture 2, Free cutting steel													
5	M10 x 1	–	M5	–	5	22	6	6.0	14	–	250	12	22120.0065
6	M12 x 1,5	–	M6	–	6	26	10	6.5	19	–	250	19	22120.0066
8	M16 x 1,5	–	M8	–	8	34	12	11.5	28	–	250	46	22120.0068
10	M20 x 1,5	–	M8	–	10	43	12	23.0	54	–	250	87	22120.0070
with knob – picture 1, Stainless steel													
5	M10 x 1	21	–	45.0	5	22	–	6.0	14	-30	80	17	22120.0445
6	M12 x 1,5	25	–	54.5	6	26	–	6.5	19	-30	80	27	22120.0446
8	M16 x 1,5	31	–	69.0	8	34	–	11.5	28	-30	80	63	22120.0448
10	M20 x 1,5	31	–	80.0	10	41	–	23.0	54	-30	80	104	22120.0450

¹⁾ statistical average value

d ₁ -0.02 -0.05	d ₂	Dimensions						Spring load ¹⁾		min. max.		[g]	Art. No.			
		d ₃	d ₄	l ₁ ~	l ₂ min.	l ₃	l ₄	F ₁ ~	F ₂ ~	[°C]						
[mm]													[N]	[°C]	[g]	
without knob – picture 2, Stainless steel																
5	M10 x 1	–	M5	–	5	22	6	6.0	14	–	250	12	22120.0465			
6	M12 x 1,5	–	M6	–	6	26	10	6.5	19	–	250	19	22120.0466			
8	M16 x 1,5	–	M8	–	8	34	12	11.5	28	–	250	46	22120.0468			
10	M20 x 1,5	–	M8	–	10	43	12	23.0	54	–	250	87	22120.0470			

¹⁾ statistical average value

Accessories

	Dimensions		Wrench size		[g]	Art. No.
	d ₂	[mm]	[mm]	[mm]		
Lock nuts ISO 8675 (DIN 439), Steel						
	M10 x 1		16		5.2	22120.0115
	M12 x 1,5		18		7.5	22120.0116
	M16 x 1,5		24		15.0	22120.0118
	M20 x 1,5		30		32.0	22120.0120
Lock nuts ISO 8675 (DIN 439), Stainless steel						
	M10 x 1		16		5.2	22120.0515
	M12 x 1,5		18		7.5	22120.0516
	M16 x 1,5		24		15.0	22120.0518
	M20 x 1,5		30		32.0	22120.0520
assembly tool, Steel						
	M10 x 1		–		9.3	22120.0955
	M12 x 1,5		–		14.0	22120.0956
	M16 x 1,5		–		25.0	22120.0958
	M20 x 1,5		–		27.0	22120.0960

Application example

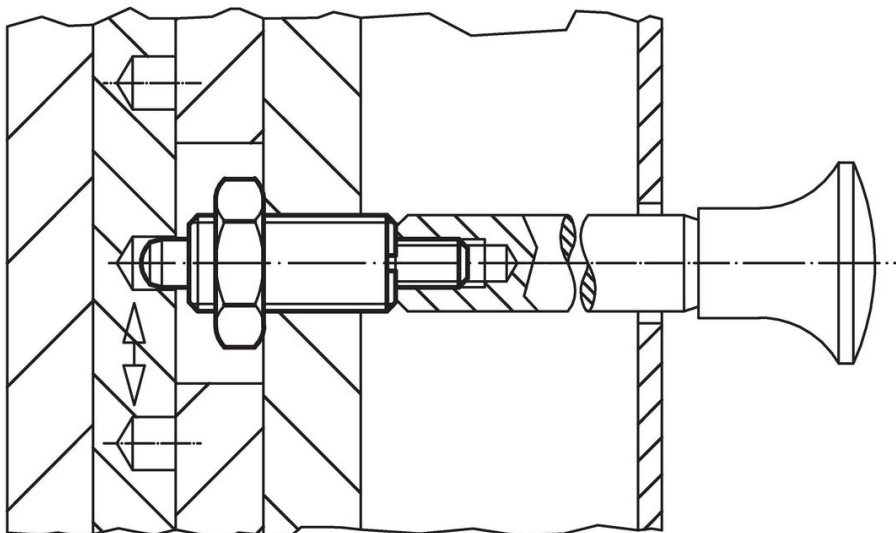

Compliance

For detailed compliance information please select the desired article number.