

Clamping Cubes • semi-finished

EH 1908.



Product Description

Material

- Grey cast iron GG

More information

Notes

Special plates on request.

Further products

- Threaded Lifting Pins, self-locking

Drawing

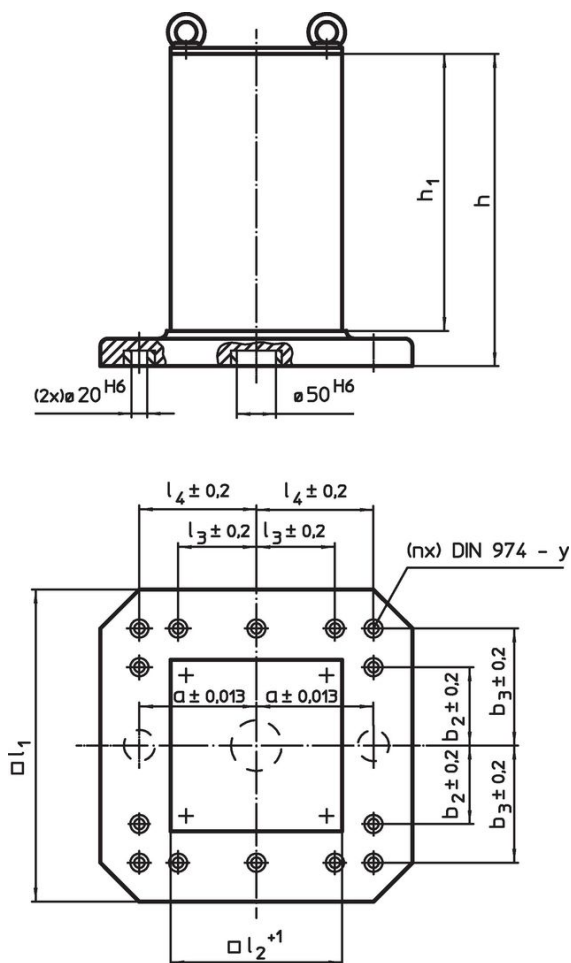

Order information

l ₁	l ₂ +1	h ₁	h	Dimensions					y	For screws	Number of fastening holes n	📦 [kg]	Art. No.			
				a ±0.013	b ₂ ±0.2	b ₃ ±0.2	l ₃ ±0.2	l ₄ ±0.2								
													[mm]	[mm]		
400	231	358	408	150	–	150	–	150	12	M12	4	100	1908.210			
500	331	510	565	200	–	200	–	200	12	M12	6	209	1908.410			
630	451	640	700	200	200	300	200	300	16	M16	8	495	1908.610			

Application example

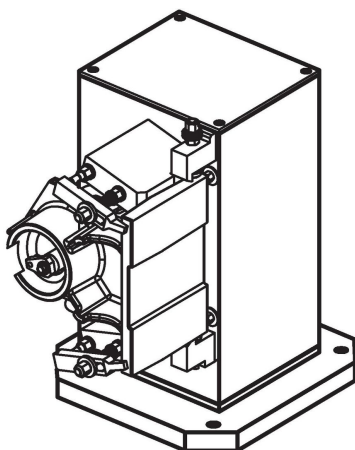

Compliance

RoHS compliant

Contains lead - compliant according to exceptions 6a / 6b / 6c.

Contains SVHC substances >0,1% w/w

Contains lead - SVHC list [REACH] as of 27.06.2024.

Contains Proposition 65 substances



Lead can cause cancer and reproductive harm from exposure
<https://www.P65Warnings.ca.gov/>

Free from Conflict Minerals

This product does not contain any substances designated as "conflict minerals" such as tantalum, tin, gold or tungsten from the Democratic Republic of Congo or adjacent countries.