

## Pull-Down Sets • high

EH 1703.



### Product Description

- Pull-down elements are suitable for clamping and pulling down clamping surfaces that are unmachined or pre-machined onto the guideway or onto the supplied seating pins
  - This way workpieces can be clamped almost exactly parallel to the guideway for machining
  - The direct contact to the seating pins largely reduces vibrations in the workpiece
- Supplied in handycase consisting of:
- 4 x wedge adapters, high (Art. No. 1703.310)
  - 4 x bolts, high M 10 x 45 mm (Art. No. 1703.330)
  - 4 x wedge elements, 4 point (Art. No. 1703.340)
  - 4 x wedge elements, microgripper (Art. No. 1703.350)
  - 4 x clamping bolts 48 mm (Art. No. 1703.440)
  - 4 x clamping bolts 34 mm (Art. No. 1703.420)

### Material

- On request

### Drawing

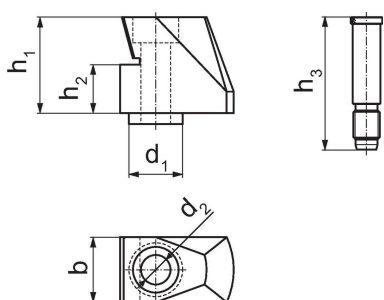

### Order information

Jaw width [mm]	b	d <sub>1</sub>	d <sub>2</sub>	Dimensions			[g]	Art. No.
				h <sub>1</sub> [mm]	h <sub>2</sub>	h <sub>3</sub>		
125	24	20	11	35.7	18	34/48	148	1703.200

### Compliance

#### RoHS compliant

Compliant according to Directive 2011/65/EU and Directive 2015/863.

#### Does not contain SVHC substances

No SVHC substances with more than 0.1% w/w contained - SVHC list [REACH] as of 27.06.2024.

#### Does not contain Proposition 65 substances

No Proposition 65 substances included.

<https://www.P65Warnings.ca.gov/>

#### Free from Conflict Minerals

This product does not contain any substances designated as "conflict minerals" such as tantalum, tin, gold or tungsten from the Democratic Republic of Congo or adjacent countries.