

Hinges • Zinc die-cast, with indexing positions

25164.0005



Product Description

Hinges from zinc die-cast with indexing positions hold door and covers in fixed positions. It avoids undesired automatic closing or opening. This is an advantage for example when filling machines and facilities or during maintenance and repairs.

The version with the indexing positions -3° and 117° (picture 2) also ensures that the door or cover presses slightly against the housing frame by the -3° when closed.

These hinges from zinc die-cast are characterised by their simple and timeless design.

Material

Body

- Zinc die-cast, plastic coated, silver, similar to RAL 9006, matt structure

Axis

- Stainless steel 1.4305

Spring

- Spring steel wire

More information

Further products

- Spacer Plates, for hinges
- Threaded Plates, for hinges

Drawing

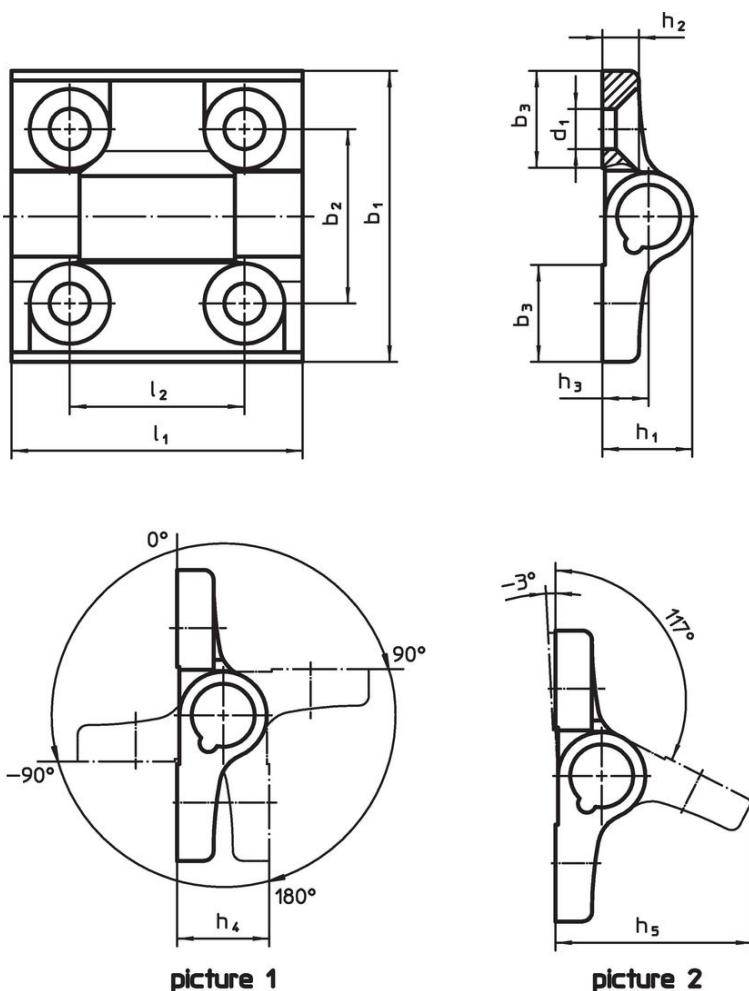

picture 1

picture 2

Order information

Dimensions											max. [°C]	[g]	Art. No.	
b ₁	l ₁	b ₂	b ₃	d ₁	h ₁	h ₂	h ₃	h ₄	h ₅	l ₂				
indexing positions -90° , 0° , 90° and 180° – picture 1, Zinc die-cast, silver														
60	60	36	20	8.3	18.5	7.5	9.5	19	40.5	36	80	152	25164.0005	

Compliance

RoHS compliant

Contains lead - compliant according to exceptions 6a / 6b / 6c.

Contains SVHC substances >0,1% w/w

Contains lead - SVHC list [REACH] as of 27.06.2024.

Contains Proposition 65 substances



Lead can cause cancer and reproductive harm from exposure
<https://www.P65Warnings.ca.gov/>

Free from Conflict Minerals

This product does not contain any substances designated as "conflict minerals" such as tantalum, tin, gold or tungsten from the Democratic Republic of Congo or adjacent countries.