

Clamping Devices Actima

23260.0005



Product Description

The compact clamping element can be converted between pull and push clamping strain, depending on the model. The travel path is 10 mm. Within the short clamp travel of 2 mm, self-locking occurs in any position. The maximum permitted clamping force is 4.9 kN.

Material

Housing

- Thermoplastic, black

Body

- Steel, blackened

Ball knob

- DIN 7708 - thermosetting plastic (PF 31), red similar to RAL 3003

Accessories

- Steel, blackened



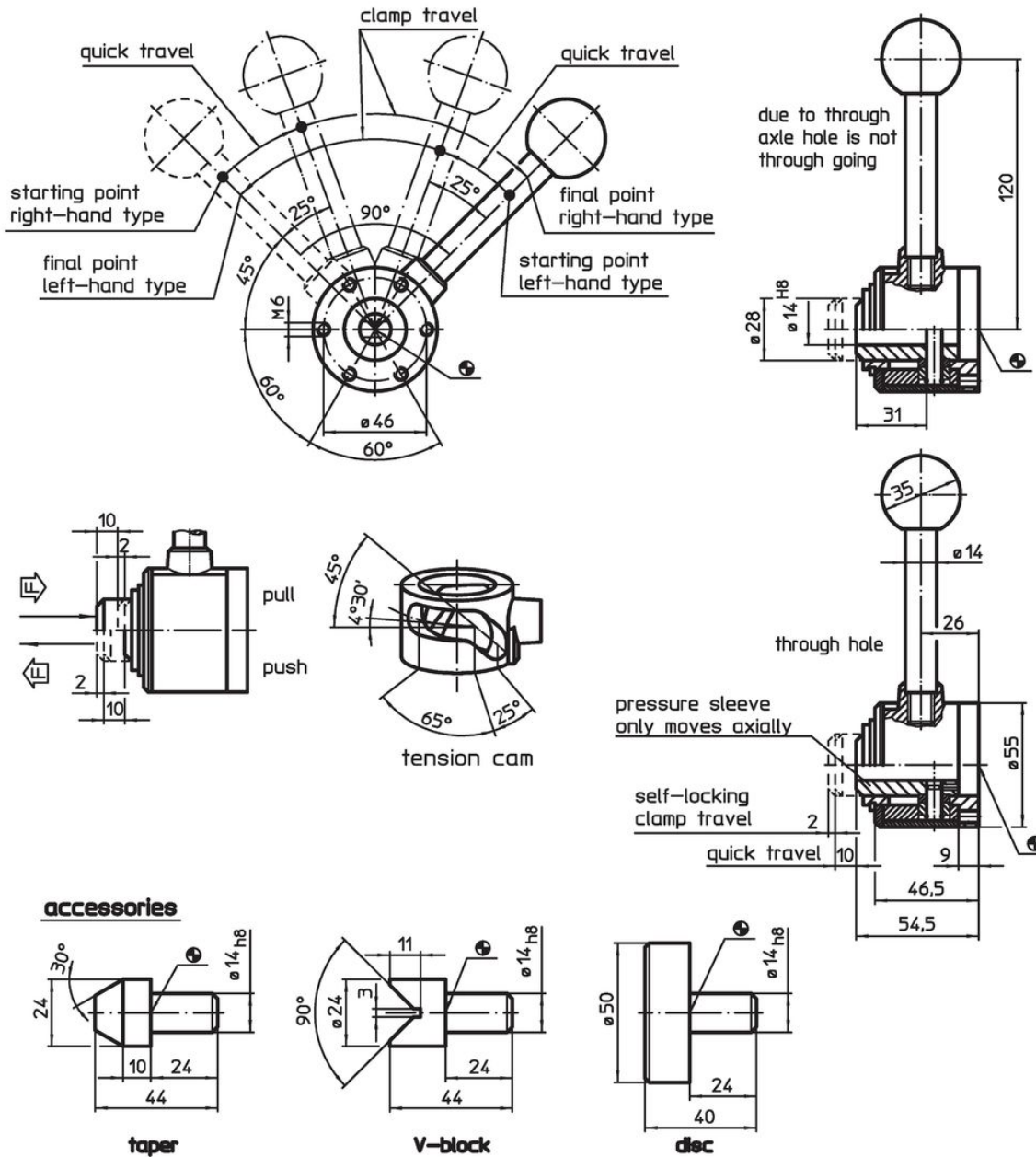

Drawing



Order information

Travel path [mm]	s Clamping way [mm]	Clamping force max. [kN]	 [g]	Art. No.
pull to left, with transverse axis in the bore				
10	2	4.9	749	23260.0005

Accessories

	 [g]	Art. No.
Disc		
	270	23260.0042
taper		
	85	23260.0044
V-block		
	82	23260.0046

Application example

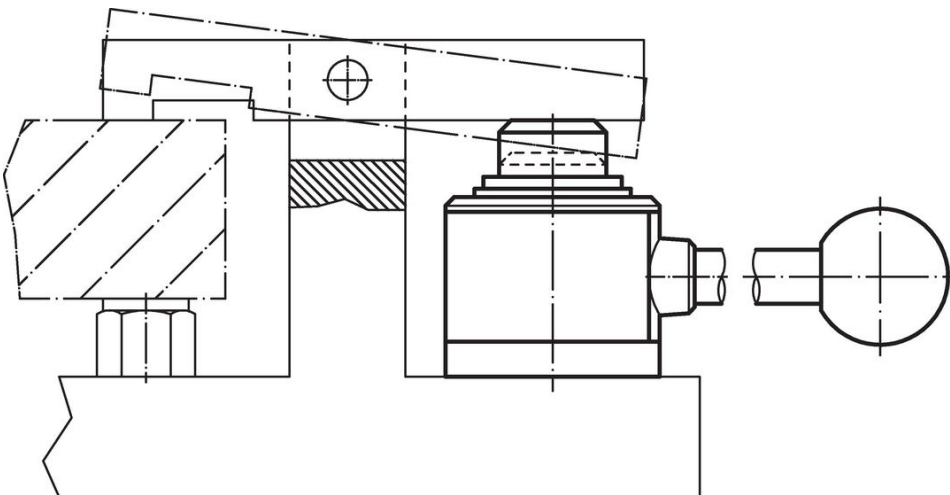

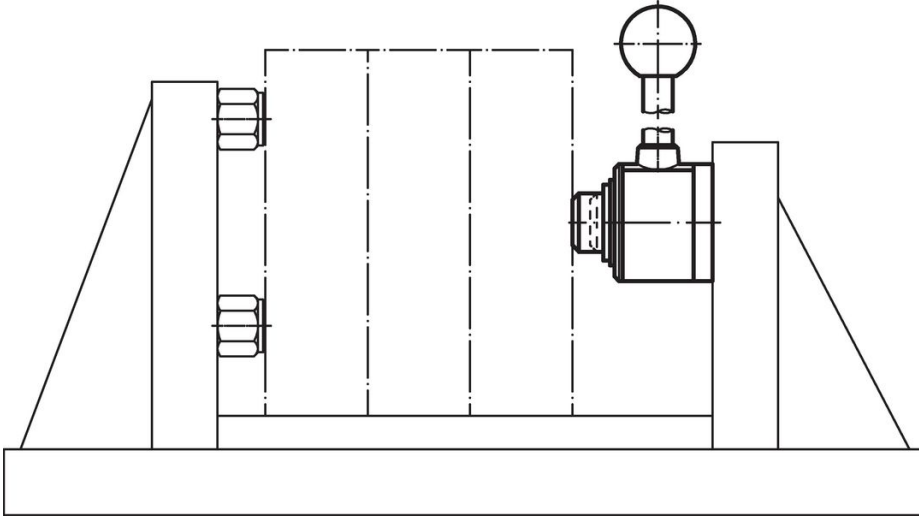

Compliance

RoHS compliant

Contains lead - compliant according to exceptions 6a / 6b / 6c.

Contains SVHC substances >0,1% w/w

Contains lead - SVHC list [REACH] as of 23.01.2024.

Contains Proposition 65 substances



Lead can cause cancer and reproductive harm from exposure
<https://www.P65Warnings.ca.gov/>

Free from Conflict Minerals

This product does not contain any substances designated as "conflict minerals" such as tantalum, tin, gold or tungsten from the Democratic Republic of Congo or adjacent countries.