

## Lateral Plungers · with thread, without seal

22150.0352



### Product Description

To be used for positioning and applying pressure, e.g. during painting and sandblasting.

#### Material

##### Body

- Steel, zinc-plated by galvanization

##### Spring

- Steel, zinc-plated by galvanization

##### Pin

- Steel, case-hardened, zinc-plated by galvanization

#### Assembly

Lateral plungers are installed by screwing in by means of a mounting tool.

Formula for calculating the center distance for the mounting hole:

$$l_0 = z/2 + w + x,$$

$l_0$  = center distance,

$y$  = workpiece height,

$w$  = workpiece length,

$x$  = coordinate dimension,

$s$  = stroke,

$z$  = stop diameter

Calculation dimension  $x$ :

$y$  greater than or equal to  $l_2 - d_2/2$ ,

then  $x = d_2/2 - s$

(value  $x$  for this case see table)

or

$y$  smaller than  $l_2 - d_2/2$ ,

then  $x = d_2/2 - s - [(l_2 - d_2/2 - y) * 0,123]$

#### Characteristic

Version heavy spring load = spring from steel, zinc-plated by galvanization

### Drawing

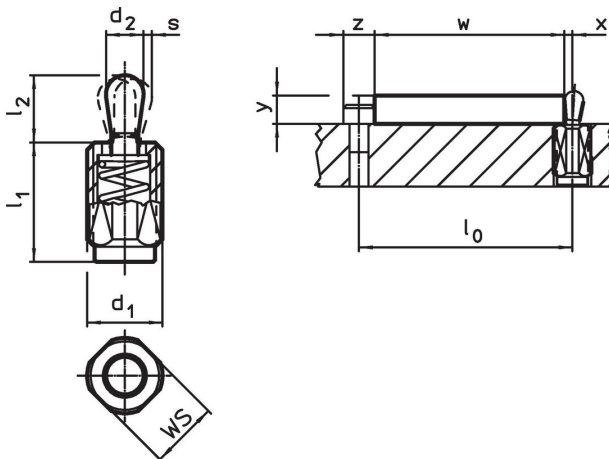

### Order information

d <sub>1</sub> [mm]	Dimensions		d <sub>2</sub> [mm]	l <sub>2</sub> [mm]	Stroke s [mm]	WS [mm]	x <sup>1)</sup> [mm]	max. [°C]	[g]	Art. No.
	l <sub>1</sub> -2	Spring load F max. <sup>2)</sup> [N]								
<b>Pin: Steel/Heavy spring load</b>										
M18 x 1,5	18	200	10	16.9	1.6	16	3.4	250	21	22150.0352

<sup>1)</sup> If the workpiece height (y) is less than l<sub>2</sub>-d<sub>2</sub>/2, the coordinate dimension (x) must be calculated.

<sup>2)</sup> statistical average value

### Accessories

	Dimensions d <sub>1</sub> [mm]	[g]	Art. No.
<b>assembly tool</b>			
	M18 x 1,5	137	22150.0822

### Application example

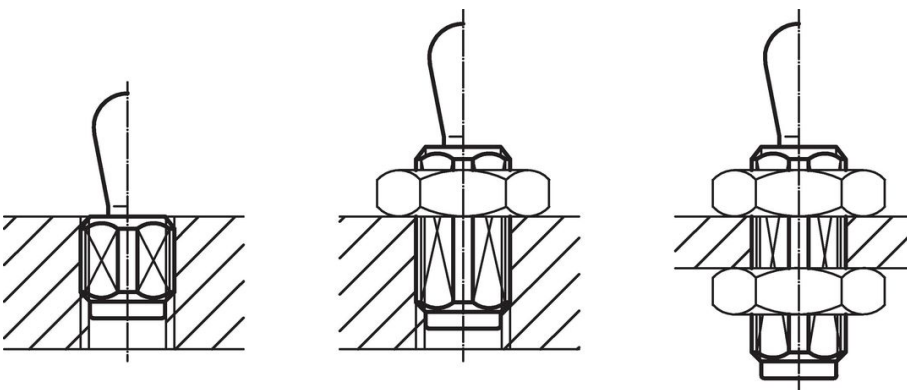

### Compliance

#### RoHS compliant

Contains lead - compliant according to exceptions 6a / 6b / 6c.

#### Contains SVHC substances >0,1% w/w

Contains lead - SVHC list [REACH] as of 27.06.2024.

#### Contains Proposition 65 substances



Lead can cause cancer and reproductive harm from exposure  
<https://www.P65Warnings.ca.gov/>

#### Free from Conflict Minerals

This product does not contain any substances designated as "conflict minerals" such as tantalum, tin, gold or tungsten from the Democratic Republic of Congo or adjacent countries.