

Lateral Plungers · with thread, without seal

22150.0336



Product Description

To be used for positioning and applying pressure, e.g. during painting and sandblasting.

Material

Body

- Steel, zinc-plated by galvanization

Spring

- Steel, zinc-plated by galvanization

Pin

- Steel, case-hardened, zinc-plated by galvanization

Assembly

Lateral plungers are installed by screwing in by means of a mounting tool.
Formula for calculating the center distance for the mounting hole:

$$l_0 = z/2 + w + x,$$

l_0 = center distance,

y = workpiece height,

w = workpiece length,

x = coordinate dimension,

s = stroke,

z = stop diameter

Calculation dimension x :

y greater than or equal to $l_2 - d_2/2$,

then $x = d_2/2 - s$

or

y smaller than $l_2 - d_2/2$,

then $x = d_2/2 - s - [(l_2 - d_2/2 - y) * 0,123]$

Characteristic

Version heavy spring load = spring from steel, zinc-plated by galvanization

Drawing

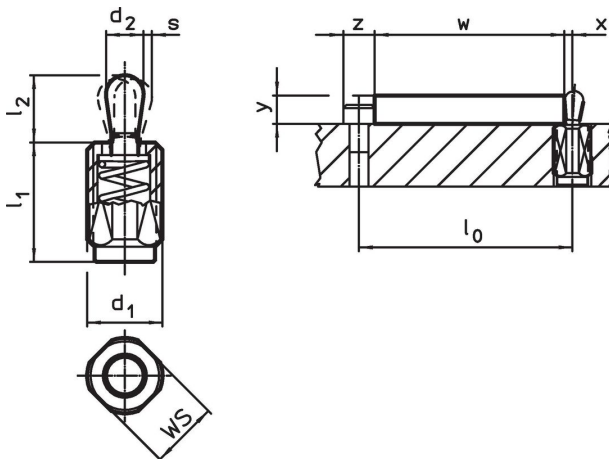

Order information

d ₁	l ₁ -2	Dimensions Spring load F max. ²⁾ ~	d ₂	l ₂	Stroke s	WS	x ¹⁾	max.	Art. No.	
										[mm]
Pin: Steel/Heavy spring load										
M12	19	100	6	10.4	1	10	2	250	7.7	22150.0336

¹⁾ If the workpiece height (y) is less than l₂-d₂/2, the coordinate dimension (x) must be calculated.

²⁾ statistical average value

Accessories

assembly tool	Dimensions d ₁ [mm]	[g]	Art. No.

Application example



Compliance

RoHS compliant

Contains lead - compliant according to exceptions 6a / 6b / 6c.

Contains SVHC substances >0,1% w/w

Contains lead - SVHC list [REACH] as of 23.01.2024.

Contains Proposition 65 substances



Lead can cause cancer and reproductive harm from exposure
<https://www.P65Warnings.ca.gov/>

Free from Conflict Minerals

This product does not contain any substances designated as "conflict minerals" such as tantalum, tin, gold or tungsten from the Democratic Republic of Congo or adjacent countries.